

Version: V1.02

operating instruction

QCW welding laser external touch screen-P series



First of all, I would like to thank your company for choosing our pulse laser products! Note it in the use instruction manual0perating method and precautions of the pulse laser. forTo use the device correctly, please read this [manual] carefully and keep this [manual] properly.

quotation

You are welcome to use the pulse welding laser products developed and produced by our company. In order to facilitate the better use and maintenance of your laser equipment, we have compiled this document. Due to the product update process, the document will inevitably make mistakes. If you have any comments and suggestions from users in the use process, please give you advice to help us continue to revise and improve, so that we can provide you with better products and services. Please carefully read the operating instruction manual for external touch screen of pulse welding laser provided by our company to be familiar with the operation and maintenance of this equipment. We highly recommend that operators read page 4 of this manual before operating the equipment.

This manual will be used as a random attachment to provide important operational, security and other information to our existing or potential clients.

Simple operation can achieve precision welding

Product characteristics

- Our company adopts laser real-time power feedback control and arbitrary waveform control function, which can correspond to various workpieces, to achieve high-quality and stable processing effect.
- Through 16 processing specifications and waveform control functions, it can correspond to various workpieces.
- Specification switching at high speed. Can instantly switch specifications, can perform high speed high quality welding.
- Using the homogenization optical system, the solder point can be processed with a small diameter.
- Laser output, choose multi-channel P 4 series, can achieve up to 4 differences (optional).
- In the simultaneous divergence mode, each divergence can get a uniform output power. Easy operation and maintenance.
- Wiring and operation are more simple and easy than before.
- Enter the specification on the LCD screen to conduct a simple and correct

operation.

- Equipped with rich input and output terminals (signals), it is easily connected with various automation equipment.
- Through the online energy monitoring function, the laser vibration output energy (J) and the average energy (W) energy can be monitored. In order to carry out more adequate quality management, it also has the upper and lower limits of the laser vibration output energy determination function.
- Using high-precision Q BH optical fiber, you can choose up to 10M, optical cable, in order to meet the diversified needs.
- Through the external communication functions (optional), the laser device specification, monitoring value and other data can be centrally managed. Small in size, it is conducive to the improvement of the workshop environment.
- Choose a 10.1-inch HD screen, as a two-in-one function of welding process monitoring and laser system.
- This product is air cooled series, do not need external cooling water, intelligent air cooling pipe system, energy saving and efficient.

Precautions for use

security information

According to the classification of laser products standard by GB7247.1-2001 (IEC60825-1:1993), this product belongs to four types of laser products, which can produce diffuse reflection, which may cause life injury or fire. Before using the machine, please carefully read the safety precautions to ensure the correct and safe operation of the machine.

In this instruction we provide you with important product considerations and other reference information. To ensure your personal safety and ensure the best performance of the product, please follow the following warnings and other operating specifications included in this manual.

- Our pulse laser is a Class IV laser product. Before accessing the AC power supply, make sure that the 220VAC power supply is connected correctly. The misconnected power supply will damage the laser.
- Ensure to use AC power with reliable grounding and overcurrent protection. Ensure sure the laser is reliably grounded to avoid possible personnel damage.
- Do not disassemble the laser because there are no product parts or accessories available to the user. All maintenance or repair work can only be carried out by our company professionals in the factory.
- The location of the posted warning signs, needs to be vigilant and cautious operation.
- Avoid placing flammable and explosive volatiles such as gasoline, alcohol and other volatile products in the laser system operation area, and ensure that the operation area is well ventilated.
- Carefully check whether the input cable and output optical fiber armored cable of the laser are in good condition, whether the signal control connector is inserted in place, and then confirm that everything is correct. The damaged parts and the wrong operation will lead to irreparable damage to the laser.

- Ensure that all laser safety glasses are worn throughout operating the machine. Even with laser safety glasses, it is strictly prohibited to watch the laser output head directly. The laser wavelength is 1080nm, and the laser safety grade is Class Class4 products. It is recommended to use the laser protection glasses that can protect from 1080nm band and protect from grade OD5.
- Our company shall not be liable for any personnel injury and machine damage caused by improper installation, debugging, unnecessary maintenance, and failure to follow the provisions and instructions specified in this manual.



警告



- a) Never use naked eyes to look directly at any form of laser beam to avoid damage, which may cause blindness when serious!



- b) Do not extend your hand or other body into the processing area, or it may burn your skin!



- c) Enter the laser processing control area!



- d) Carefully weld the mirror materials to avoid laser mirror reflection and cause damage to the equipment and operators!



- e) Keep the operator's eyes at the same height as the laser beam light path. Use the high-temperature resistant laser absorber as a baffle to isolate the laser.



- f) Please do not touch the workpiece that is being welded or just welded. The surface temperature is very high and it may burn you!



- g) It is forbidden to be repeatedly processed at the same position of the material, and the long-time processing at the same position may cause fire!



注意

1. Users are forbidden to disassemble or modify the equipment by themselves. Non-professional safety accidents, equipment failure caused by disassembly, repair, refit the equipment do not belong to the scope of warranty!
2. Do not use the equipment with vibration, impact or strong source of electromagnetic noise. Vibration or electromagnetic interference may affect the machining accuracy and may damage the equipment.
3. Use the equipment in areas with adequate space around and good ventilation. If the working space of the equipment is poorly ventilated, the temperature rise inside the equipment may damage the equipment.
4. Regular maintenance and maintenance of the equipment to prevent any potential hazards.



危險



1. Do not touch the inside of the chassis on startup. The equipment supplies 220V, there is high voltage danger in the chassis!



2. Please operate the electrical equipment with only one hand as far as possible to prevent the current from forming a circuit on the human body.



3. Please use the specified wire and cable. If the insufficient capacity wire, cable or connection method is not correct, a fire or electric shock will be caused.



4. Do not damage the power wires and cables. Cable damage can cause electric shock, short circuit and even cause fire.



5. Do not short circuit the power output lead of the laser or ground!



6. Switches and buttons should be carefully operated one by one in order to avoid equipment failure caused by switching multiple switches at the same time.



7. Do not use the equipment in a wet environment, the electrical moisture may cause short circuit or leakage.



8. The protection ground wire of the equipment must be grounded by a third party, and the grounding protection must be reliable, otherwise, the electric shock may be caused during the failure or electricity leakage.



9. It is forbidden to put the water-filled container on the welding machine. If the water is sprinkled on the welding machine, it may cause electric shock or fire.



10. The laser power supply can be repaired only for 5 minutes after cutting off the high-voltage power supply.



Figure 1-Laser protection glasses



Tags pictures	Tagged information
	<p>Laser label</p>
	<p>Safety warning (located on the laser rear panel)</p>

Table 1: Laser Safety Label

catalogue

Home page of the operating instruction manual.....	- 1 -
quotation.....	- 2 -
Product characteristics.....	- 3 -
security information.....	- 4 -
catalogue.....	- 8 -
一、 on-product information.....	- 10 -
1. Product description.....	- 10 -
2,50W~120W lasers.....	- 10 -
3,150W laser.....	- 12 -
4.100W dual-light path laser.....	- 13 -
二、 technical parameter.....	- 14 -
三、 Laser size diagram.....	- 17 -
四、 method of erection.....	- 19 -
1、 container loading list.....	- 20 -
2、 OOBA.....	- 20 -
3、 Install the host.....	- 20 -
4、 Laser output head mounting.....	- 21 -
5、 External screen and touch installation.....	- 22 -
6、 Urgent stop installation.....	- 23 -
7、 AC installation.....	- 23 -
五、 Initial power.....	- 25 -
1、 Check before charging.....	- 25 -
2、 Laser boot operation.....	- 25 -
3. Laser turns off the operation.....	- 25 -
六、 External interface.....	- 26 -
1,50W~120W laser interface.....	- 26 -
1.1、 DB25 interface.....	- 26 -
1.2、 DB9 interface.....	- 28 -
1.3、 Plug-in-type terminal EXT-IN interface.....	- 30 -
1.4、 Plug-in-type terminal EXT-OUT interface.....	- 30 -
2.150W laser interface.....	- 32 -
2.1. DB37 interface.....	- 32 -
2.2. DB15 interface.....	- 33 -
2.3. DB9 interface.....	- 33 -
3.100W dual-optical circuit laser interface.....	- 34 -
3.1. DB37 interface.....	- 34 -
七、 Control the display and operation.....	- 35 -
1,50W~120W lasers.....	- 36 -
1.1、 Operation page.....	- 36 -
1.2、 Password login and modification.....	- 37 -

1.3、 Main interface function.....	- 38 -
1.4、 Display Control Edit.....	- 39 -
1.5、 Peak adjustment.....	- 40 -
1.6、 Parameter editing.....	- 41 -
1.7、 Red light setting.....	- 42 -
1.8、 Weld editor.....	- 43 -
1.9、 PWM pattern.....	- 44 -
1.10、 Light gate control.....	- 45 -
1.11、 Warning information records.....	- 46 -
1.12、 String number input.....	- 47 -
1.13、 Screensaver interface.....	- 48 -
2,150W laser.....	- 49 -
2.1. Operation page.....	- 49 -
3.100W dual-light path laser.....	- 50 -
3.1. Operation page.....	- 50 -
4. Dual-machine single screen (one to two).....	- 51 -
4.1. Operation page.....	- 51 -
4.2. Screensaver interface.....	- 52 -
八、 fault treatment.....	- 53 -
九、 Optical output fiber terminals are equipped with air-cooled QBH terminals.....	- 55 -
十、 work pattern.....	- 56 -
十一、 Fiber-optic end inspection and cleaning guide.....	- 57 -
十二、 Service and maintenance.....	- 62 -
1. Instructions for maintenance.....	- 62 -
2. Warranty restrictions.....	- 62 -
3. Service statement.....	- 62 -

1. on-product information

1、 product description

Compared with the traditional laser, our pulse laser has high conversion efficiency, compact structure

Free adjustment and maintenance, optical fiber flexible guide output and many other advantages, is the principle of industrial laser welding and other applications

Want the light source.

Our pulse laser is an optimized combination of light, machine, electric and soft. Through the control interface and our company standard

The software can monitor the operation state of the laser and alarm, and enter the operation data

Line collection records. The laser adopts air-cooled radiator design, low energy consumption, compact structure, convenient for customers

Integrated use.

2、 The 50W~120W lasers

A, front panel

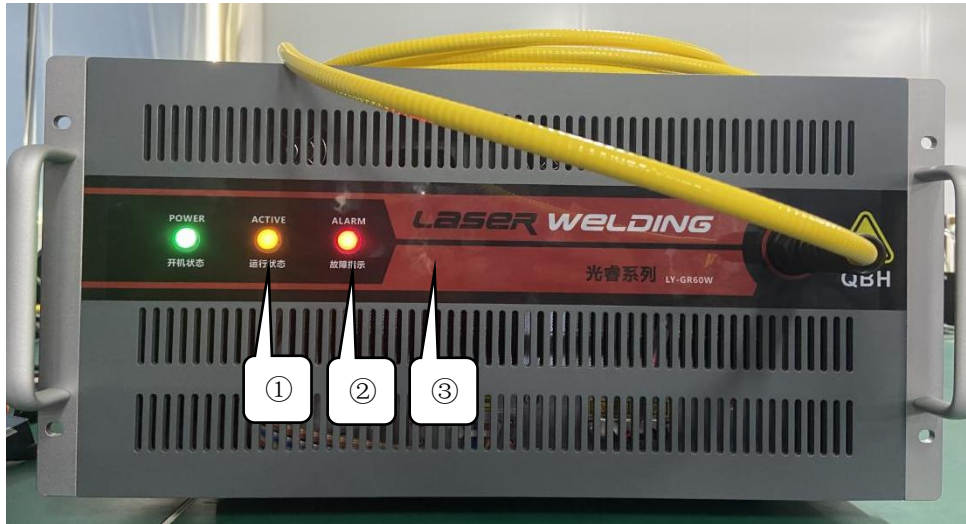

Figure 1-Physical picture of the front panel of the 1 / 50W~120W laser

- ① Green light turns on normally (flashing)
- ② Yellow operating status (flashing)
- ③ red light fault warning (constant light)

B, back panel

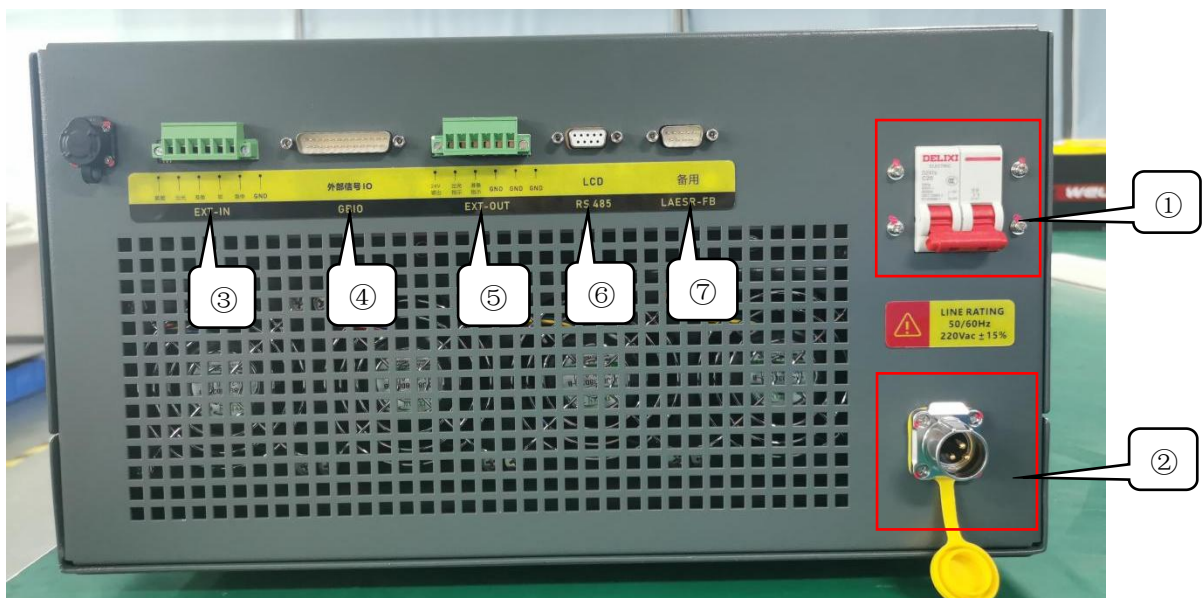

Figure 1-Back panel physical picture of 2 / 50W~120W laser

① laser main power switch;

The ② power supply connection inlet;

③ 6P plug-in wiring port EXT-IN [for details, see Figure 6-5];

④ DB25 interface [see Figure 6-1] for details;

⑤ 6P plug-in wiring port EXT-OUT [for details, see Figure 6-6];

⑥ DB9 interface [see Figure 6-3];

⑦ reserve;

3,150W laser

A, front panel



Figure 1-Physical picture of the front panel of the 3 / 150W laser

① laser power master switch; (other same as 50W~120W);

B、back panel

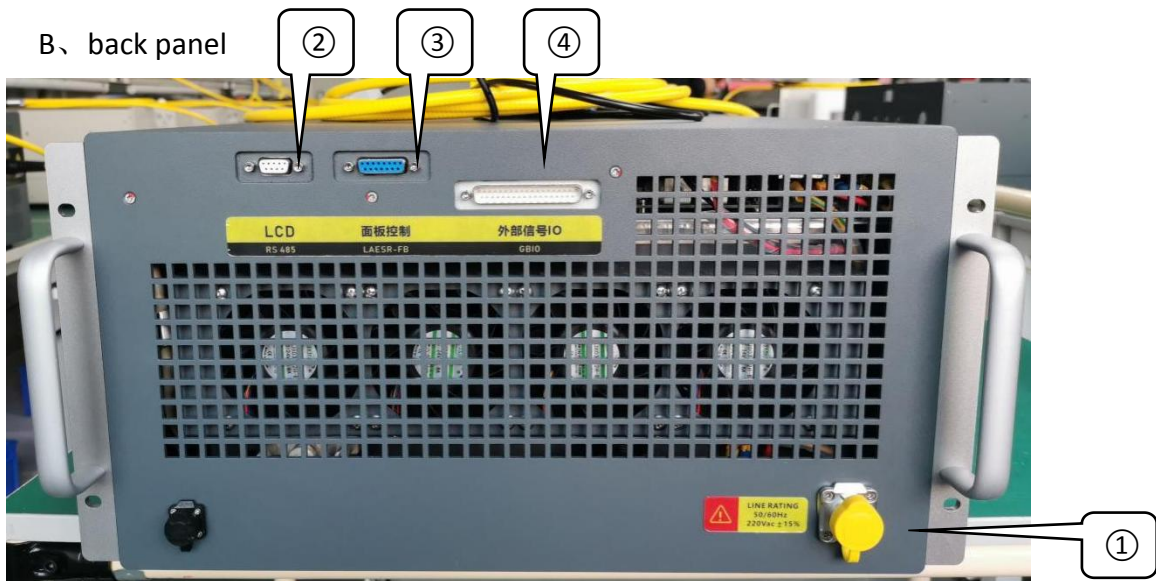

Figure 1-Physical panel of 4 / 150W laser

The ① power supply connection inlet;

② DB9 interface [see Table 6-6 for details];

③ DB15 interface / standby [see Table 6-5] for details;

④ DB37 interface [see Table 6-4] for details;

4.100W dual-light path laser

A, front panel



Figure 1-Physical picture of the front of the 5 / 100W dual-light circuit

laser

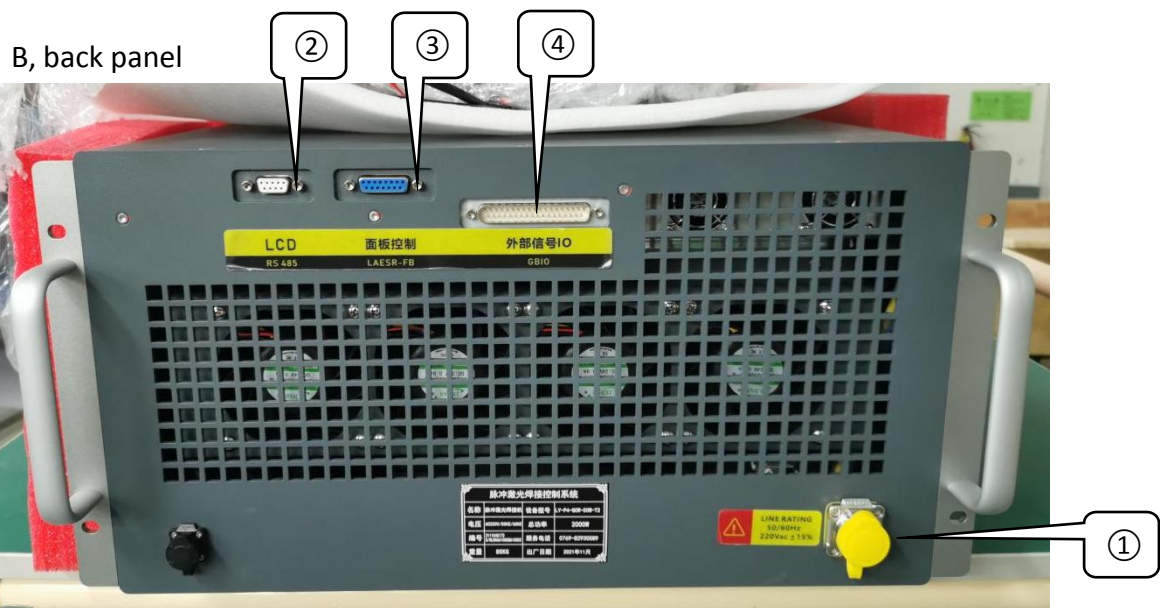

Figure 1-Physical picture of the rear panel of the 6 / 100W dual-light circuit

laser

The ① power supply connection inlet;

② DB9 interface [see Table 6-6 for details];

③ DB15 interface / standby [see Figure 6-5] for details;

④ DB37 interface [see Table 6-7] for details;

2. technical parameter

Optical characteristic parameter table						
order number	natural parameter	W count	least value	representative value	crest value	unit
1	Pulse-mode maximum peak power	50W		500		W
		60W		600		
		100W		1000		
		120W		1200		
		150W		1500		
2	PWM mode maximum power	50W		150		W
		60W		180		
		100W		300		
		120W		360		
		150W		450		
3	Average power (pulse)	50W		50		W
		60W		60		
		100W		100		
		120W		120		
		150W		150		
4	Maximum pulse energy	50W		5		J
		60W		6		
		100W		10		
		120W		12		
		150W		15		
5	Power regulation range	50W	10		100	%
		60W	10		100	
		100W	10		100	
		120W	10		100	
		150W	10		100	
6	modulating frequency	50W	10		20000	HZ
		60W	10		20000	
		100W	10		20000	
		120W	10		20000	
		150W	10		20000	
7	Range of duty cycle	50W	10		50	%
		60W	10		50	
		100W	10		50	
		120W	10		50	
		150W	10		50	
8	Pulse wide range	50W	0.02		50	ms
		60W	0.02		50	

		100W	0.02		50	
		120W	0.02		50	
		150W	0.02		50	
9	The central wavelength	50W		1080		nm
		60W		1080		
		100W		1080		
		120W		1080		
		150W		1080		
10	Light and light efficiency	50W		65		%
		60W		65		
		100W		65		
		120W		65		
		150W		65		
11	Electric light efficiency of the whole machine	50W		30		%
		60W		30		
		100W		30		
		120W		30		
		150W		30		
12	Spectral Bandwidth (3dB)	50W		3		nm
		60W		3		
		100W		3		
		120W		3		
		150W		3		
13	power stability	50W		1.5		%
		60W		1.5		
		100W		1.5		
		120W		1.5		
		150W		1.5		
14	Indicate red light power	50W		200		μ W
		60W		200		
		100W		200		
		120W		200		
		150W		200		
15	Fiber cable length	50W		6.5	10	m
		60W		6.5	10	
		100W		6.5	10	
		120W		6.5	10	
		150W		6.5	10	
16	Optical fiber cable bending radius	50W		200		mm
		60W		200		
		100W		200		
		120W		200		
		150W		200		

17	Output fiber core diameter	20 (50,100,200 Customizable)	μm
18	The beam mass M ²	20 μ m=1.3 50 μ m= (2-4) 100 μ m= (8-12) (Optional)	μm
19	Output method	QBH	
20	cooling-down method	forced air cooling	
21	Operating environment temperature range	10~35	°C
22	humidity	<70	%
23	Storage temperature	0-60	°C
24	50W~120W Size (Wide X deep X high)	483X624X244 (with handle)	mm
25	150W / Dual light path dimensions (width X deep X high)	483X767X251.5 (including handle)	mm
26	50W~120W weight	58	Kg
27	The 150W / dual-light road weight	85	Kg

Table 2-1 Characteristic Parameters Table

三、Laser size diagram

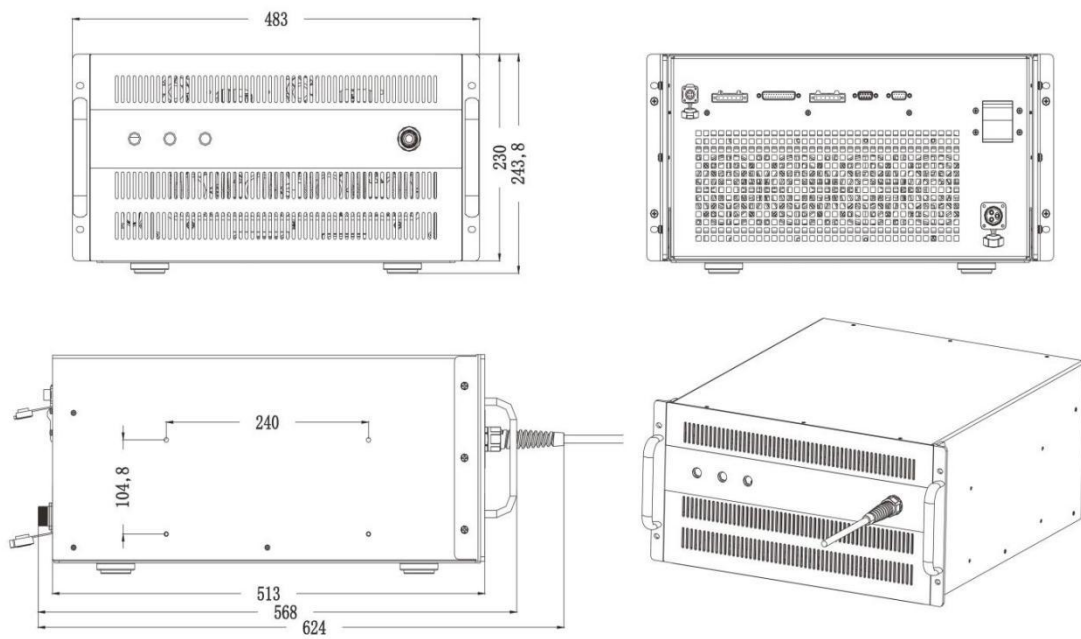
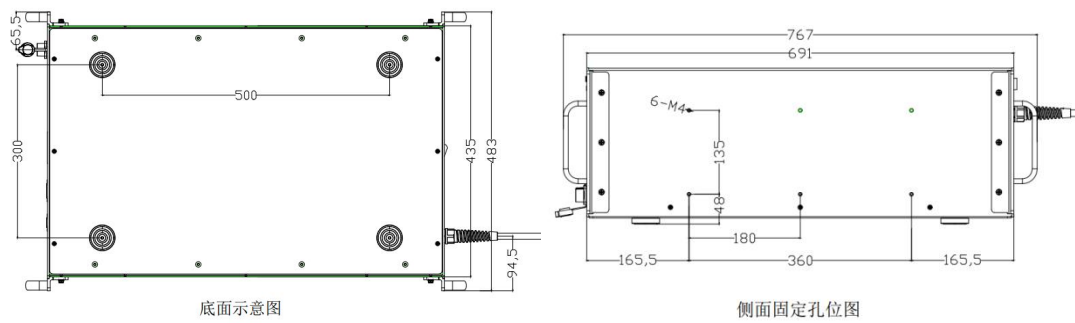

Figure 3-1 / 50W~120W laser dimensions diagram



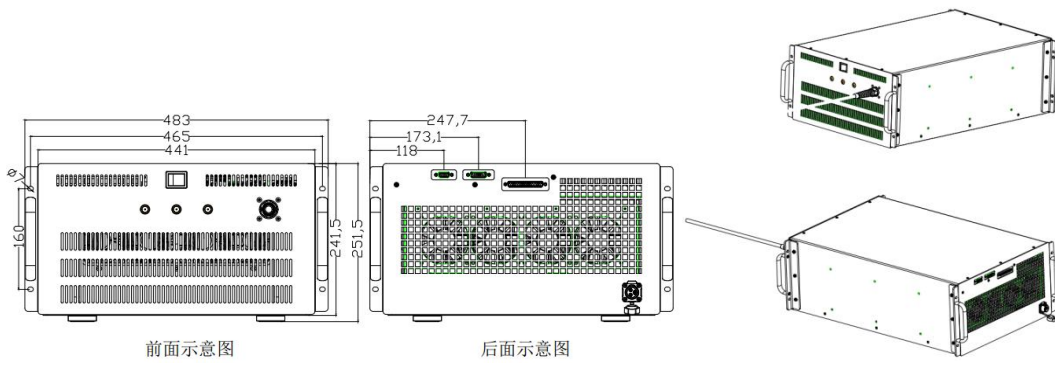

Figure 3-2 / 150W Laser dimensions diagram

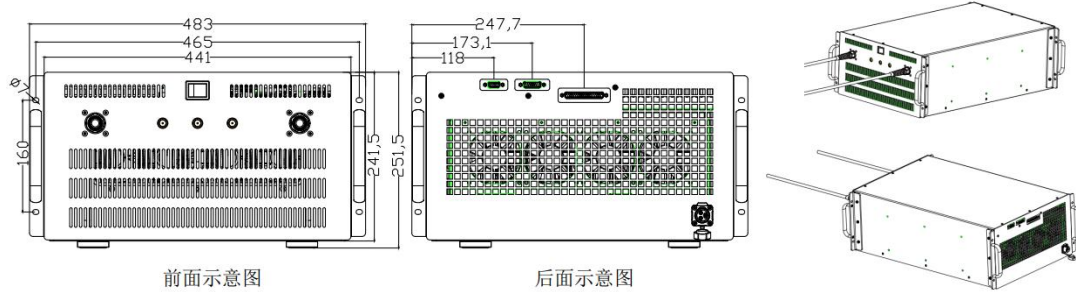
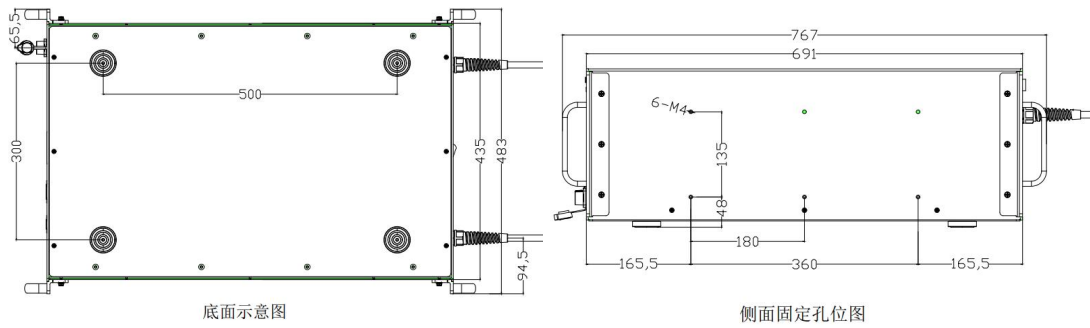

Figure 3-3 / 100W dual-light path laser dimensions diagram

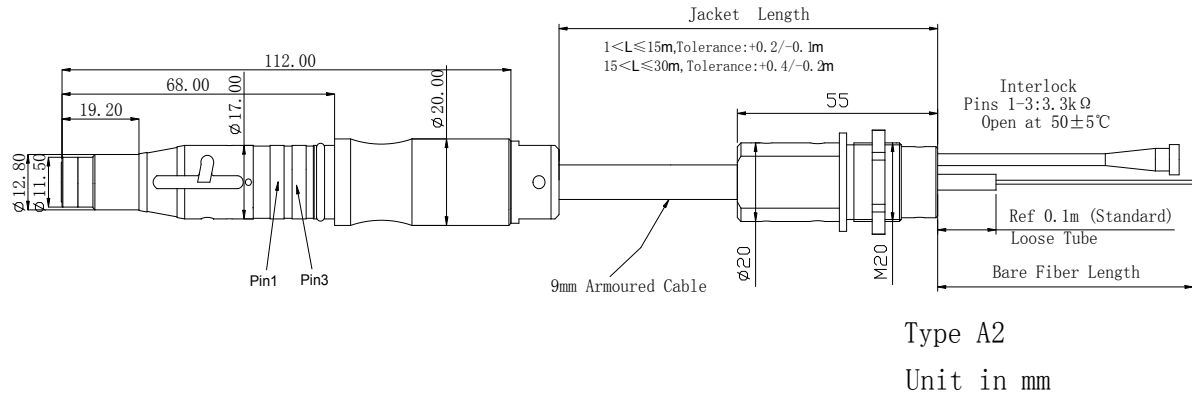

Figure 3-4 / Laser output head dimensions diagram

The laser output head shall be subject to the final factory product;

4. method of erection

- Ensure reliable grounding before using the laser.
- Verify that the laser and the output head are placed on a horizontal and smooth operating platform. If the laser is placed on a metal platform, make good electrical contact between the laser and the mounting platform and be well grounded.
- Ensure that all components of the laser do not fall and then vibrate strongly, and not damage the laser.
- The minimum bending radius of the laser's output armored cable shall not be less than 20 cm, whether in transportation, storage, or in the working condition.
- Before installation, please confirm that the external AC switch, the leakage air switch on the rear panel of the laser are off, and the emergency stop switch, button switch and key switch on the front panel of the laser are off.
- The laser output head is not installed when the laser is running.
- Do not directly watch the laser output head, and make sure to wear the laser

for eye protection when operating the laser.

- Do not expose the product to high humidity (humidity > 95%).
- Do not allow this product to work below the ambient dew point temperature. (As shown in Table 4-1)

环境温度 and 相对湿度下的恒定露点表									
环境温度℃	最大相对湿度								
	20%	30%	40%	50%	60%	70%	80%	90%	95%
20	-3.5	2	6	9	12	14.5	16.5	18	19
25	0.5	6	10.5	14	16.5	19	21	23	24
30	4.6	10.5	15	18.5	21.5	24	26	28	29
35	8.5	15	19.5	23	26	28.5	31	33	34
40	13	20	24	27.5	31	33.5	36	38	39
激光器工作温度范围									

Table 4-1 Control Table of constant dew points at ambient temperature and relative humidity

1、 container loading list

[Refer to the packing list in the packing box]

2、 OOPA

Our company uses specially designed packaging materials and boxes to ensure that the laser is always fully protected during transportation. Nevertheless, in order to prevent unpredictable situations during transportation, users still need to carefully check whether the box is properly placed, the outside for collision, cracking, and flooding before unpacking. In the external box, please inform us to handle it as soon as possible.

After opening the box, please check whether the packing list is consistent with the actual items. If you have any questions, please contact us timely.

3、 Install the host

Attach the laser to the stable ground platform to ensure that all components of the laser do not fall, collide, or cause strong vibration, or cause falling objects from high altitude to damage the laser.

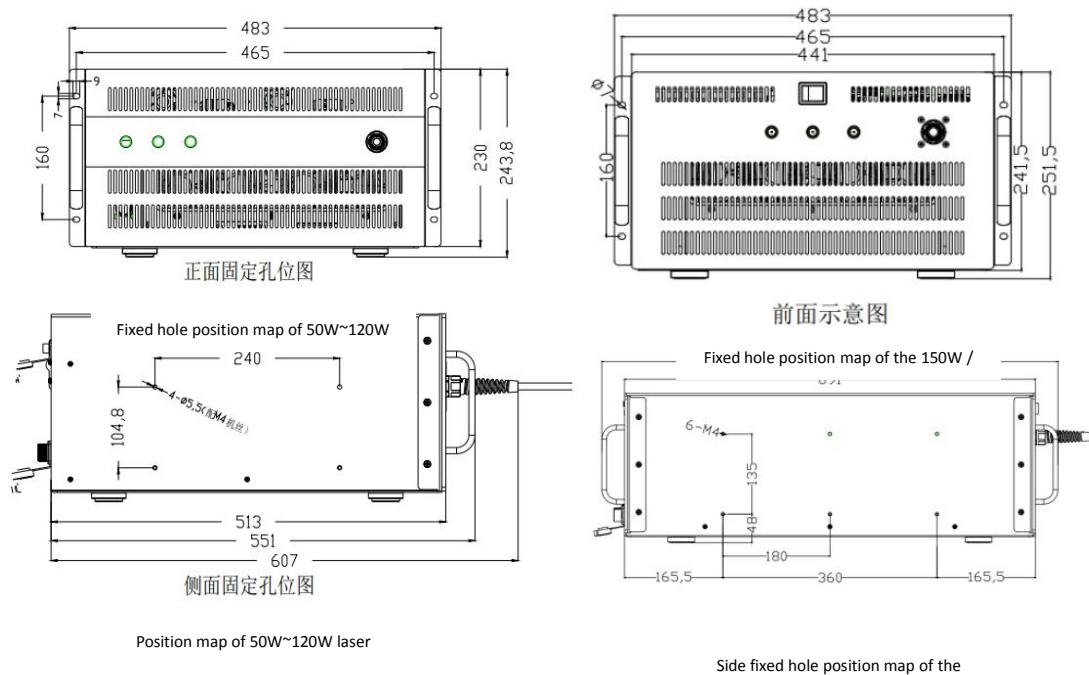

Figure 4-1 Laser mounting hole position map

4、 Laser output head mounting

Laser output head QBH is a precision optical accessory, which is vulnerable and expensive accessories, in the packaging process of the whole machine, we have specially added a protective device. The QBH section needs to be checked for clean and clean before installing welding heads or other accessories, and dust is fatal for high power laser output fittings. If necessary, clean the alcohol output surface with a purity of over 99.9% (refer to the cleaning guide). The coiled laser output cable should pay special attention to, do not twist, bend, pull the laser output cable (minimum bending radius > 200mm) and avoid the collision and vibration of the laser output head. **Laser damage caused if the user fails to follow the above operation is not covered by the warranty.**



- For the QBH output optical cable, the laser must short-connect the two copper contacts (InterLockpins) on the output head before working, otherwise the laser will not work properly. Usually, the copper contact will automatically shortconnect after the output cable is installed in the processing equipment.
- The lens of the output cable must be checked before the installation to the machining head. If the output optical cable lens is found to be unclean, the lens must be cleaned.
- Laser output optical cable belongs to the precision of optical devices, twisted or excessive bending of the output optical cable, laser output head by vibration and impact will cause irreparable damage to the laser.
- Strictly prohibit the personnel outside our company to remove the output head lens, otherwise the quality assurance is invalid.

Tips: Please choose the appropriate connector, and generally the universal connector on the market can match our QBH output head. When fitting the QBH into the connector, please set the connector flat.

Insert QBH horizontally into the locking structure of the connector, tighten and secure before erect the fixed connector.(1) Remove the plastic protective cover of the QBH output head and the external connector.(See Fig. 4-2, Q B H Operation Figure 1 and 2)

(2) The first half of the optical fiber terminal should be inserted into the external connector first. Before inserting the fiber terminal, align the red dot of the QBH terminal with the red dot of the external connector.(See Figure 4-2QBH Operation Figure 3)

(3) Gently push the QBH terminal into the connector, and rotate the roller position of

the outer connector (rotate left and then push up and then rotate left) to lock.(See Figure 4-2QBH Operation Figure 4)

Important: The connector locking device can only be operated by hand, using tools.

(1) The fiber terminal is locked in a fixed position by the connector, while ensuring that its direction is correct, and the secure interlock loop on the fiber terminal is closed only after the connector is locked.

(2) When fixing and finishing the optical cable, the minimum bending radius requirements should not be exceeded: 100mm without stress, and 200mm under stress.

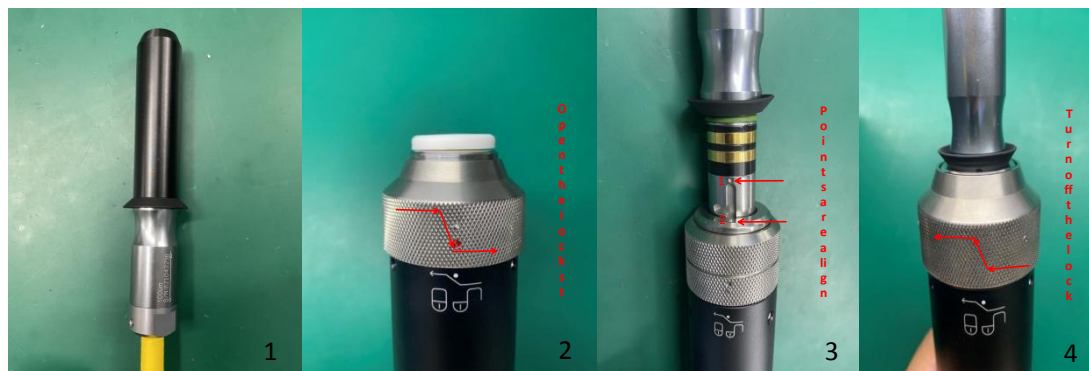

Figure 4-2 Operation diagram of QBH terminals

5. External touch screen installation

(1) Fixed the 86X86X34 slot box (optional) where the external touch screen should be installed.(See Figure 4-3 External screen Installation Operation Figure 1)

(2) Open the rear cover plate of the touch screen.(See Figure 4-3 External screen Installation Operation Figure 2)

(3) Put the touch screen connection cable (see Figure 4-3 External screen Installation Operation Figure 3) into the slot box and secure the back cover of the touch screen on the slot box with screws.(See Fig. 4-3 Installation Operation Fig. 4 and 5)

(4) Fixed to the touch screen.(See Figure 4-3 External screen Installation Operation Figure 6)



Figure 4-3 Installation operation diagram of external screen

6. Emergency installation

Position the emergency stop in a significant and accessible position, and mark it well.(See Figure 4-4 Emergency Stop button)

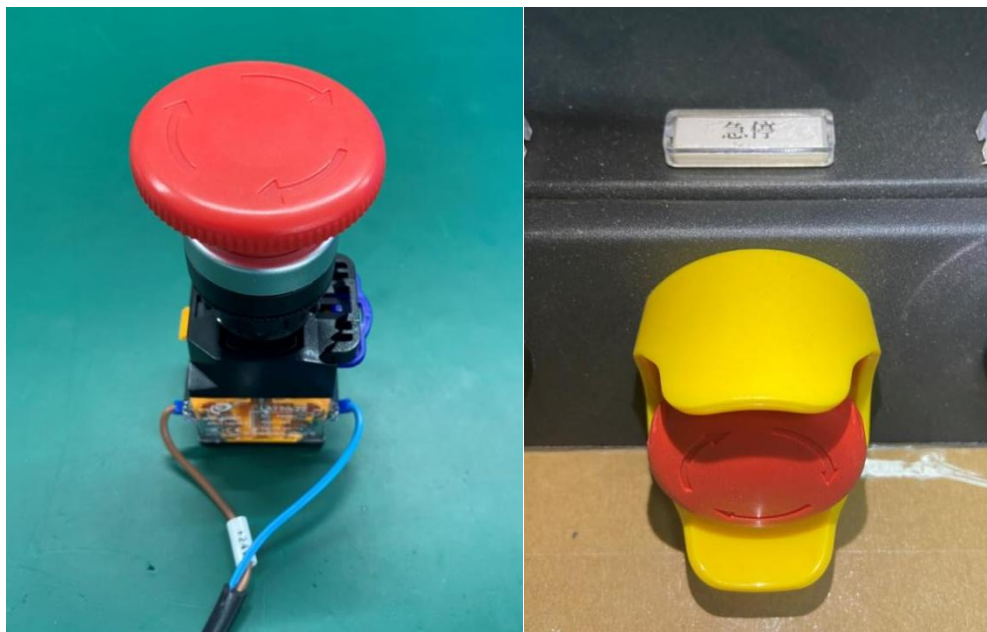

Figure 4-4 Emergency Stop button diagram

7. AC power installation:

(1) Before the first AC connection, please confirm that the leakage air switch in the rear panel of the laser chassis, the front panel key switch and the start button switch have been dialed to the off position, and the emergency stop switch is in the bounce state;

(2) The laser AC uses 3PIN aviation plug input, and its input interface is defined in Figure 4-5; the input AC specifications are shown in Table 4-3; please confirm whether the output AC meets the requirements before accessing mains; the wrong connection may directly lead to laser failure or damage; the AC connection is shown in Figure 4-6;

order number	name	description	pigment
1 Foot	battle line	City electricity L line	Brown or red
2 Foot	null line	Used N line	Blue or black
Three feet	ground lead	mainpower protection grounding PE	Yellow and green two colors

Table 4-2 AC current input wiring

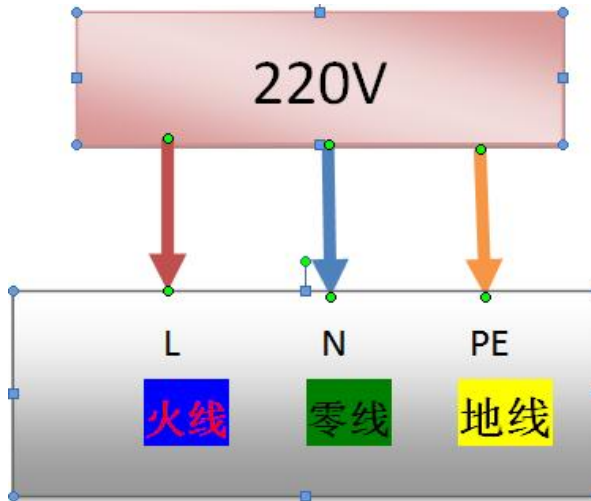

Figure 4-5 AC current input interface

order number	parameter	specifications	unit
1	Enter a valid city power value	$220 \pm 10\%$	VAC
2	Enter the mains frequency	50/60	HZ

Table 4-3 AC Power Specifications



Figure 4-6 AC electric connection diagram

五、 Initial power



Warning 警告 All electrical connections (including water connections for water-cooled products) must be powered on the product
In addition, all connections must be fastened with screws to ensure reliable operation.



Warning 警告 Do not look directly at the fiber output head during product operation and ensure you wear suitable laser safety glasses. When you move or process the transport fiber, ensure that the power to the product is disconnected.

1、 Check before charging

- (1) Whether the operation space is well ventilated, whether there is combustible, flammable, explosive, volatile products, etc.;
- (2) Whether the power grid voltage is normal; (please refer to Item 7, Chapter IV)
- (3) Whether the light exit path of the welding ejection head is blocked, and whether the interior is clean without dust;
- (4) Whether there are non-staff members in the operating area;

2、 Laser boot operation

- (1) Close the rear panel air switch;
- (2) Release the emergency stop switch;
- (3) Click "Start Power Source" to "ON"; (refer to Chapter 7)
- (4) Click external touch screen "light" to "ON" status (refer to Chapter 7)

3、 Laser shutdown operation

- (1) Click the external touch screen "light" to "OFF" status;
- (2) Click the external touch screen "Start Power source" to "OFF" status;
- (3) Turn off the rear panel air switch and cut off the laser power supply;

Air cooled products please ensure that the air path is unobstructed and the air cooled fan is in normal standby state.

VI. External interface

1. DB25 interface (50W~120W laser)

DB-25M

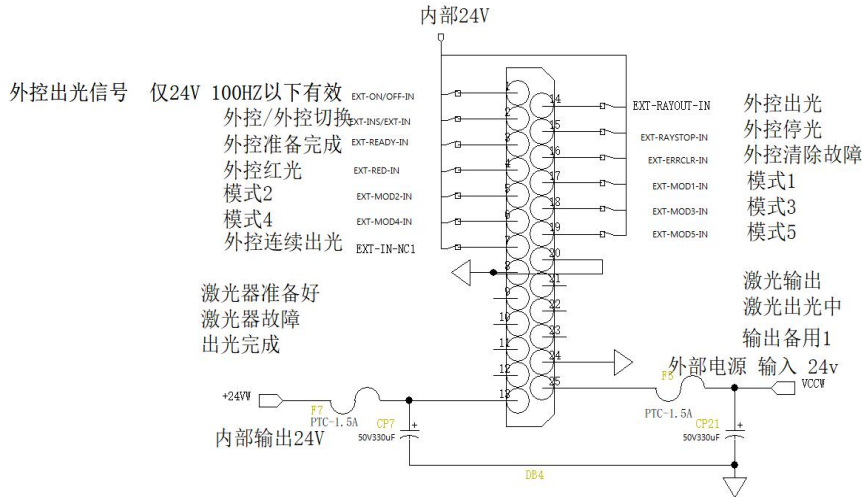

Figure 6-1 / DB25 interface definition

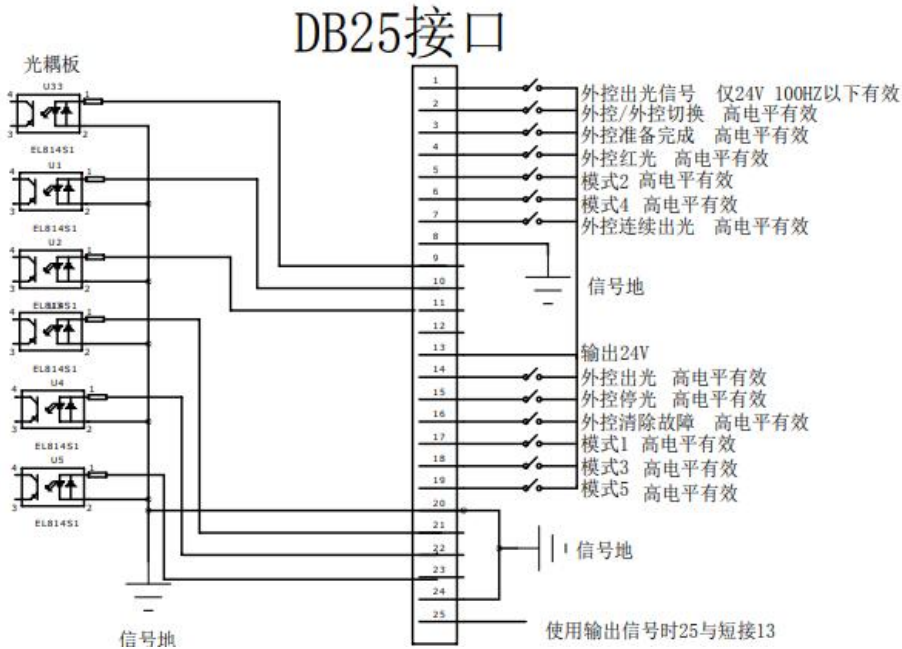

Figure 6-2 / DB25

The pin number	description
1	External control light output (only support 24V high level, frequency below 100Hz light output signal) (input)
2	External control: external control switch this bit must be valid to respond to other signals (input)
3	External control preparation is completed (no action yet) (input)
4	External control red light (input)
5	Mode 2 (Layer 2) (input)
6	Mode 4 (Layer 8) (input)
7	External control high level continuous light (high level light low level stop light) (input)
8	Signal ground
9	Laser is ready (output)
10	Laser failure (output)
11	Output: 6mS pulse (output)
12	Empty feet
13	+24V(output)
14	External control light output (single pulse light output) (input)
15	reserve
16	External control to clear fault, high level effective (input)
17	Mode 1 (Layer 1) (Input)
18	Mode 3 (Layer 4) (Input)
19	Mode 5 (Layer 16) (input)
20	Signal ground
21	Laser Output (output)
22	Laser light (output)
23	Output standby (Output)
24	Signal ground
25	External power input (5-24V without external power should be 12 or 13)
Note: All of the above signal IO ports are valid at a high level	

Table 6-1 / DB25 Interface Definitions Table

2. DB9 master head interface

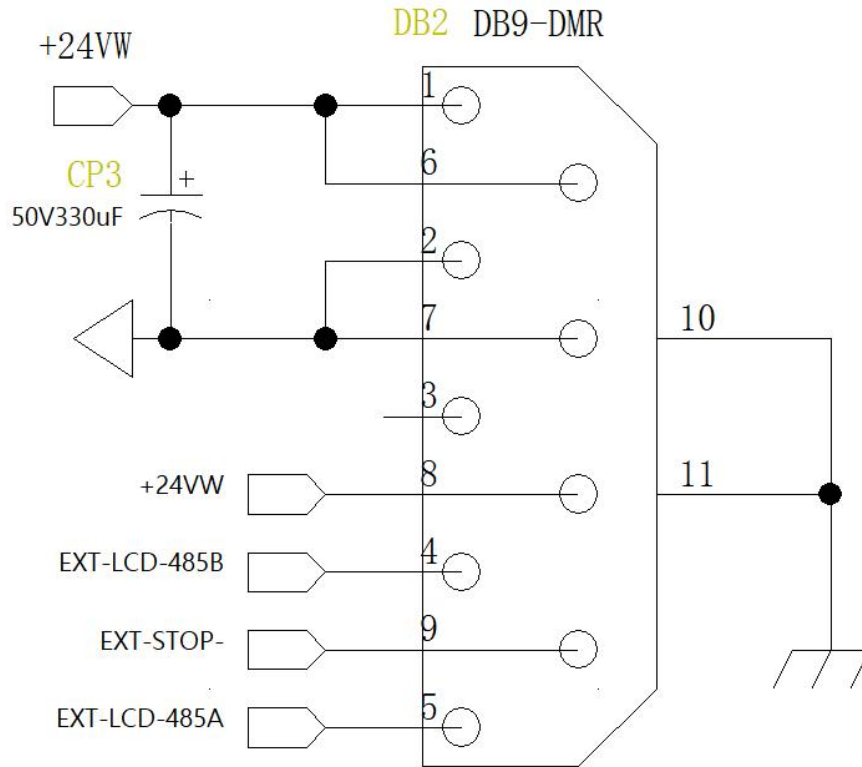
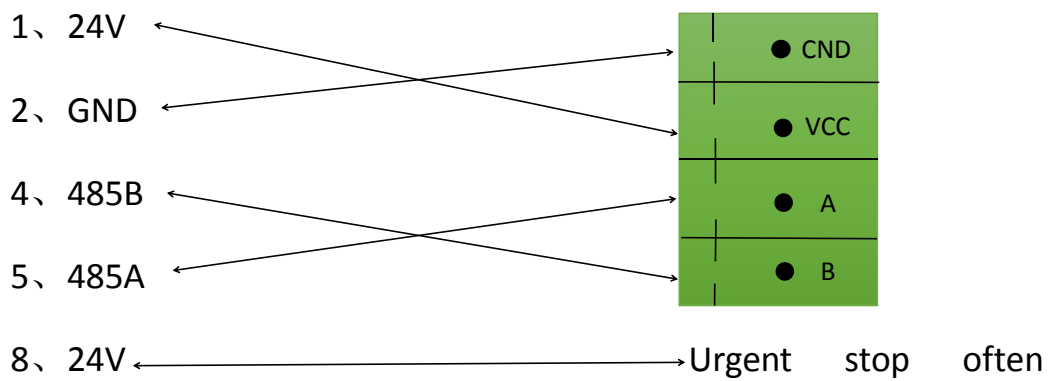

Figure 6-3 / DB9 interface definition diagram

The pin number	description
1	output 24V
2	GND
3	empty
4	485B
5	485A
6	empty
7	empty
8	output 24V
9	jerk

Table 6-2 / Definition of DB9 master head interface

DB9 wiring male header touch screen



closed 1

9、 Emergency stop Emergency stop often close 2



(Example of DB9 bus connector on back of laser) (Example of touch screen interface)

Figure 6-4 / external touch screen wiring diagram

3. Terminal EXT-IN interface (50W~120W laser)

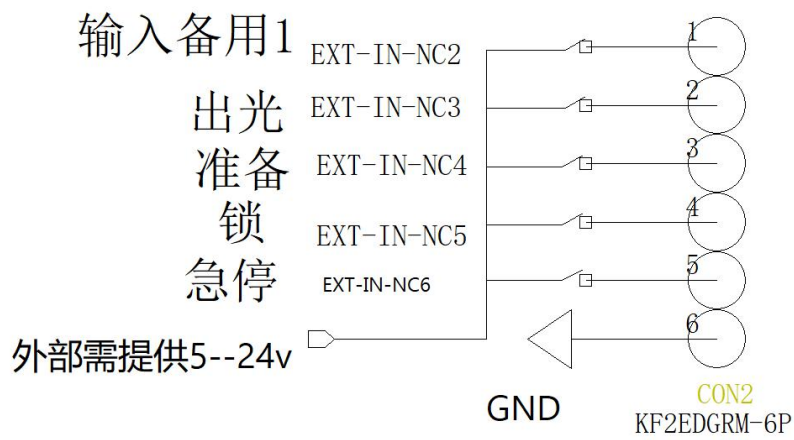

Figure 6-5 / Back panel left 1 green terminal interface definition

4. Plug-and-plug type terminal EXT-OUT interface (50W~120W laser)

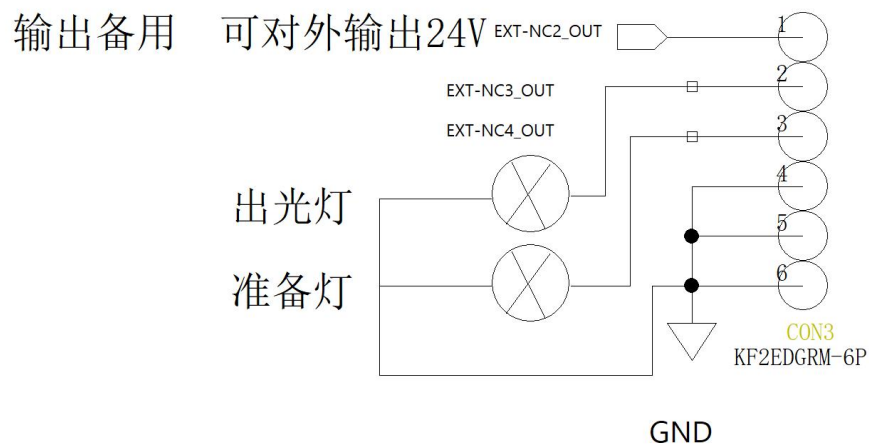

Figure 6-6 / Left 2 rear panel

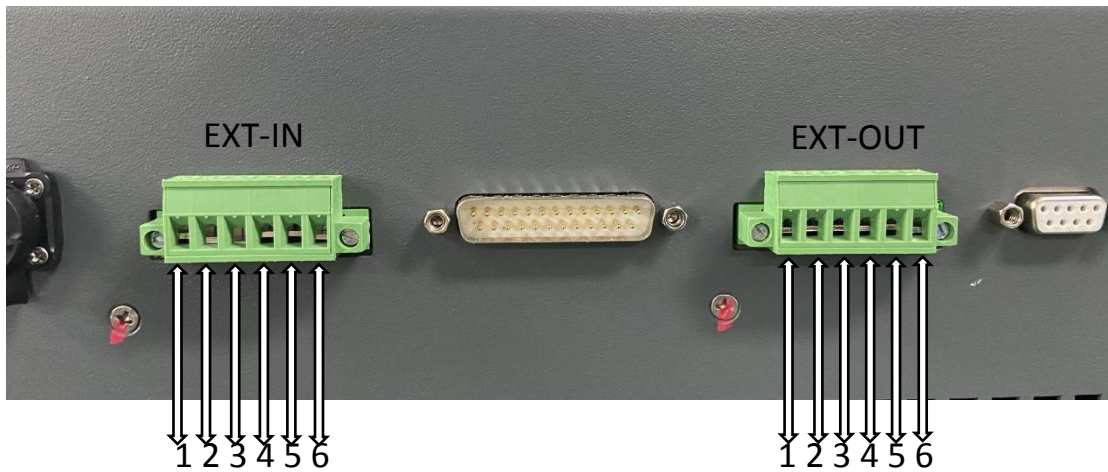

Figure 6-7 / Physical diagram of the plug-in terminal interface

The interface name	The pin number	description
EXT-IN	IN1	pedal
	IN2	glaring
	IN3	prepare
	IN4	lock
	IN5	jerk
	IN6	GND
EXT-OUT	OUT1	24V output
	OUT2	Out of light instructions
	OUT3	Prepare instructions
	OUT4	GND
	OUT5	GND
	OUT6	GND

Table 6-3 / Terminal interface definition table

5.150W laser interface

5.1. DB37 interface definition

pin	description	type	remarks
1	Laser start	import	
2	Laser stop	import	
3	glow	import	
4	Remote switch machine	import	
5	Internal control /	import	Input the high level to switch to the external
6	Layer 1	import	
7	Layer 2	import	
8	Layer 4	import	
9	External control of	import	High level out light, low level stop
10	GND Public Land	Public	
11	GND Public Land	Public	
12	Power + 24V	power	Output of 24V power supply
13	Power + 5V	power	Output of 5V power supply
14	GND Public Land	Public	
15	GND Public Land	Public	
16	be all set	output	
17	Failure output	output	
18	Laser out of light	output	
19	The light finished	output	
20	NC		
21	NC		
22	NC		
23	Out of the light	import	Enter high level ready
24	Clear the fault	import	
25	NC		
26	NC		
27	NC		
28	NC		
29	GND Public Land	Public	
30	GND Public Land	Public	
31	source VCC	import	External power input (5-24V If no external power supply, this foot should be shortened)
32	GND Public Land	Public	
33	GND Public Land	Public	
34	NC		
35	NC		
36	NC		
37	NC		

Note: All input and output interfaces are high level unless otherwise specified.

Table 6-4 / DB37-150W Interface definition table

5.2. Definition of the external DB15 interface

The pin	description	type	remarks
1	Interlock-, with 9 feet short	import	
2	Emergency stop switch, the high	import	
3	Point out the light button at	import	
4	GND Public Land	GND	
5	Power + 24V	power	output 24V
6	No.1 laser flash	output	
7	The 1st was ready	output	
8	The earth, the shell	ground	
9	interlocking +	import	
10	Keyswitch, high level effective	import	
11	NC		
12	GND Public Land	import	
13	NC		
14	NC		
15	Equipment fault lamp	output	

Table 6-5 / DB15-150W Interface definition table

5.3. External DB9 interface definition

The pin	description	type	remarks
1	Power + 24V	power output	output 24V
2	earth wire GND	GND	
3	NC		
4	Newsletter RS-485B	communication	
5	Newsletter, RS-485A	communication	
6	NC		
7	NC		
8	NC		
9	NC		

Table 6-6 / DB9-150W Interface definition table

6.100W dual-optical circuit laser interface

6.1. DB37 interface definition

pin	description	type	remarks
1	No.1 laser is started	import	
2	Laser # 1 stopped	import	
3	No.1 red light	import	
4	Remote switch (common 1 and	import	
5	Internal control / external	import	Input the high level to switch to the
6	Layer 1 of Figure 1	import	
7	Layer 12	import	
8	Layer 14	import	
9	External control of	import	High level out light, low level stop
10	GND Public Land	Public	
11	GND Public Land	Public	
12	Power + 24V	power	Output of 24V power supply
13	Power + 5V	power	Output of 5V power supply
14	GND Public Land	Public	
15	GND Public Land	Public	
16	The 1st was ready	output	
17	No.1 fault output	output	
18	Laser 1 out the light	output	
19	No.1 is out of light	output	
20	No.2 laser is started	import	
21	Laser # 2 stopped	import	
22	No.2 red light	import	
23	Light out preparation (shared by	import	Enter high level ready
24	Clear the fault (common with	import	
25	Layer 21	import	
26	Layer 22	import	
27	Layer 24	import	
28	External control of	import	High level out light, low level stop
29	GND Public Land	Public	
30	GND Public Land	Public	
31	source VCC	import	External power input (5-24V If no external power supply, this foot should be
32	GND Public Land	Public	
33	GND Public Land	Public	
34	The 2nd is ready	output	
35	No.2 fault output	output	
36	Laser # 2 is out of the light	output	
37	No.2 is out of light	output	
Note: All input and output interfaces are high level unless otherwise specified.			

Table 6-7 / DB37-100W Dual-Light Interface Definitions Table

7. Control the display and operation



Figure 7-1 Laser connection into the main interface diagram

1,50W~120W lasers



Figure 7-2 / Operation page shows

1.1 Operation page application description:

- ① long press here for 5 seconds to enter the password 6 to enter the main interface;
- The ② frequency (Hz) value shows that when the frequency is 0, the default laser is the maximum frequency;
- ③ number of times value display;
- The ④ peak (%) display;
- ⑤ Click here to select the mode, and the background can store 16 sets of modes;
- The ⑥ increases the number of peaks;
- The ⑦ reduces the number of peaks;
- ⑧ increases the number of pulse width;
- The ⑨ reduces the number of pulse widths;
- ⑩ Click here to unlock / lock, the unlock status can operate the page parameters, the lock status can not operate;
- The ⑪ sliding scroll bar can adjust the peak size;
- ⑫ internal control and external control switch keys;
- The ⑬ sliding scrolling bar can adjust the pulse width value size;
- ⑭ red light switch;
- ⑮ internal control light switch;
- ⑯ enables the light out switch, and it should start the power source before opening;
- ⑰ to start the power source switch;

Note: This page is a custom version!!!



Figure 7-3 / Password login and modification figure

1.2 Password login and modification application:

- ① Click "more" to enter the password login and serial number input;
- ② input password to log in; operator password is 1, administrator password is 6;
- ③ Enter the original password to enter the new password that you want to change;
- ④ Click "Confirm" password to modify successfully;

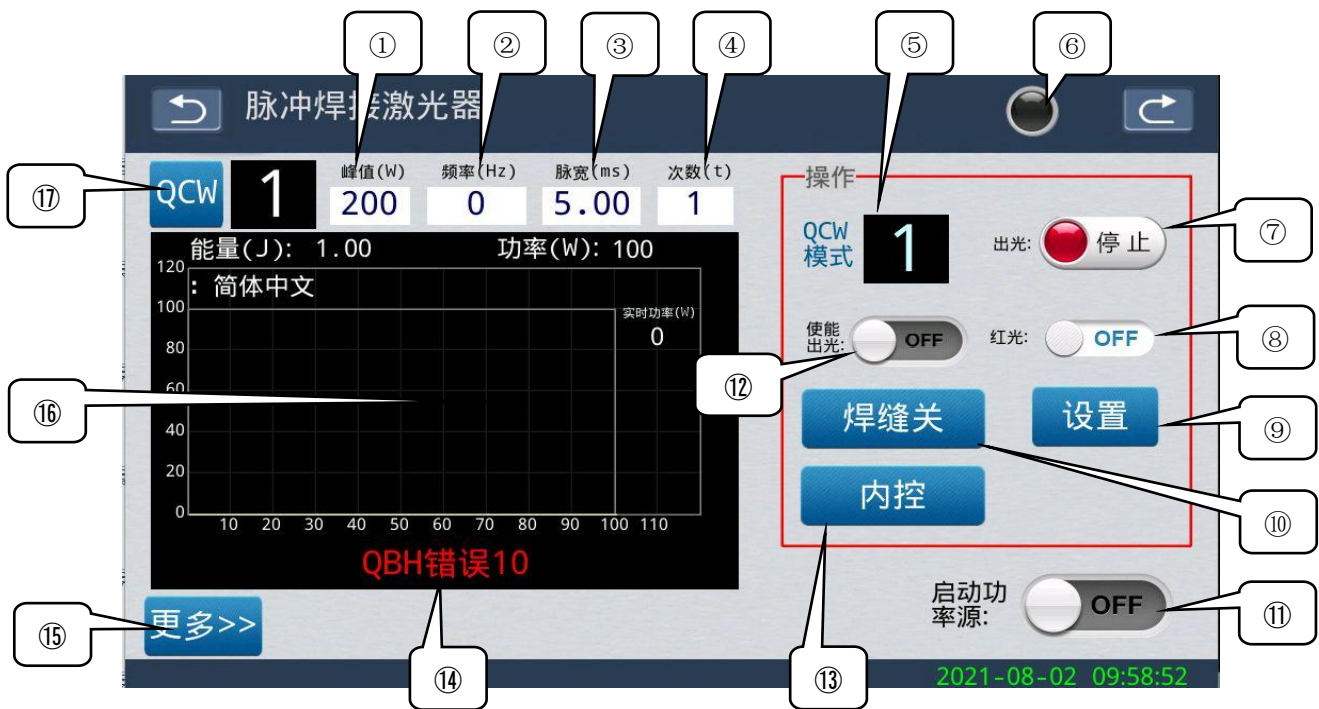

Figure 7-4 / 50W~120W main interface diagram

1.3 Description of the main interface application:

- Set and adjust the ① laser peak parameters, and adjust the step to 1;
- ② frequency parameter of pulse. When the frequency is 0, the default laser is the maximum frequency;
- Setting and adjustment of ③ pulse width parameters, the adjustment step is 0.01;
- ④ Number of light output times set for a single pulse;
- The ⑤ touches this icon to enter the waveform selection, and the background can store 16 sets of waveforms;
- ⑥ communication indicator; flashing green light indicates no communication, gray light indicates no communication;
- The ⑦ touches this icon to trigger "light" and "stop light";
- The ⑧ turns the red light on or off;
- The ⑨ can set the red light strength;
- ⑩ sets any slow rise and slow drop time, and the weld mode should be closed when single light;
- The ⑪ start-up power source key;
- ⑫ enables the light out switch, and it should start the power source before opening;
- ⑬ internal control and external control switch; changing setting parameters should be changed to internal control, internal control is touch screen control light, and external control is external DB25 / IO port control light;
- ⑭ prompts error message; click to enter the alarm information record;
- ⑮ Click "More" to enter the password login, serial number input; the password is 6;
- ⑯ set power waveform and real-time power waveform display area;
- ⑰ QCW / PWM switch key;

Note: Start laser out laser sequence: click "Start power source" click "enable light" click "light" button to give light.

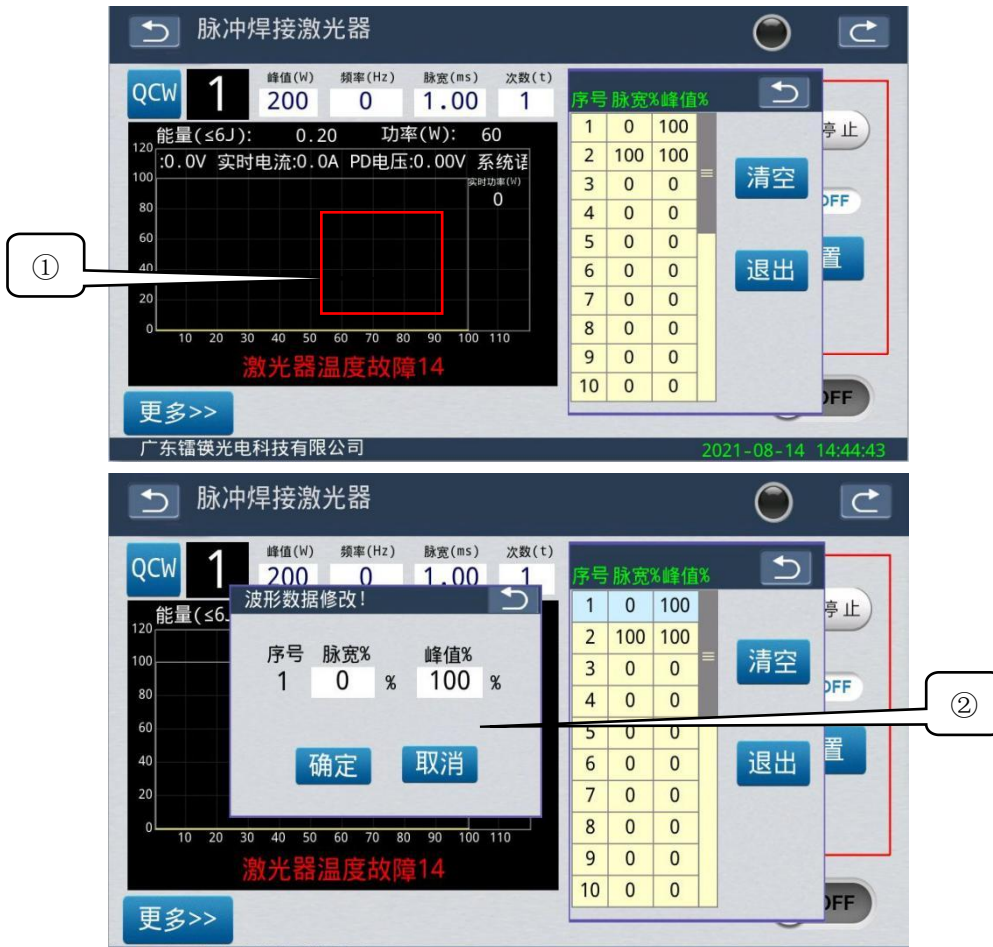

Figure 7-5 / Display control diagram

1.4 Display Control Editor:

- ① Click on this position to modify and set any arbitrary waveform;
- ② waveform editing, modified pulse width and peak value;

remarks:

Set the percentage of pulse width; if the pulse width is 10ms and 50% percentage, the actual pulse width is 5ms.

Set the percentage of the peak, and if the peak is 500W and the percentage is 50%, then the actual output is 250W.



Figure 7-6 / Peak setting diagram

1.5 Peak adjustment setting

The ① sliding scrolling bar can "adjust the peak size" or directly click on the value to modify;

② Click OK to save the number of adjusted number of peaks;



Figure 7-7 / Parameter Setting Figure

1.6 Parameter editing settings

- ① Click on the number to enter the parameter value to be set;
- ② Del delete key;
- ③ Esc Unkey;
- ④ Click the return key to save;



Figure 7-8 / Red light setting diagram

1.7 Red light setting application

- The ① "slide" scroll bar can "adjust the strength of the red light";
- ② switch switch; click to enter the switch setting;
- ③ Click to exit to return to the current page;

Note: The laser and red indicator light cannot be output simultaneously. When the laser state is out, the red light automatically turns off.



Figure 7-9 / weld setting drawing

1.8 Welding editing settings

- The ① input of the total welding time required;
- The ② shows the time of the first slow rise;
- The ③ shows the last time of the slow drop;
- ④ can be set up with any slow rise and slow drop waveform;
- ⑤ on / off slow down;
- ⑥ sets the slow rise and slow drop parameters here;



Figure 7-10 / PWM mode settings

1.9 PWM mode settings

- ① QCW / PWM mode switch;
- ② peak input;
- ③ frequency input, up to 20,000 H Z;
- ④ duty cycle input, up to 50%;

Note: The PWM laser power is 3 times that of the QCW laser power.(See Table 2-1, Item 2)



Figure 7-11 / Gate setting diagram

1.10 Light lock control setting

- ① tick here to enable the required light switch;
- ② control switch optical switch key;
- ③ gate status;



Figure 7-12 / alarm information diagram

1.11 Record of alarm information

The ① displays the alarm information record;

The ② displays the alarm information time record;

③ Click Clear to clear the alarm information;

④ Click to view the historical alarm information;



Figure 7-13 / serial number input setting diagram

1.12 Set of serial number input

- ① Click "More" to display the input password page;
- ② Enter password 6 click "Login" to enter the administrator setting entrance;
- ③ Click "serial number input" to set the serial number;
- ④ clicks "confirm" the serial number " in the serial number box to enter the serial number successfully (the serial number is valid on the same day);
- ⑤ Click "Return" to clear the alarm (refer to Fig. 7-12 alarm information);

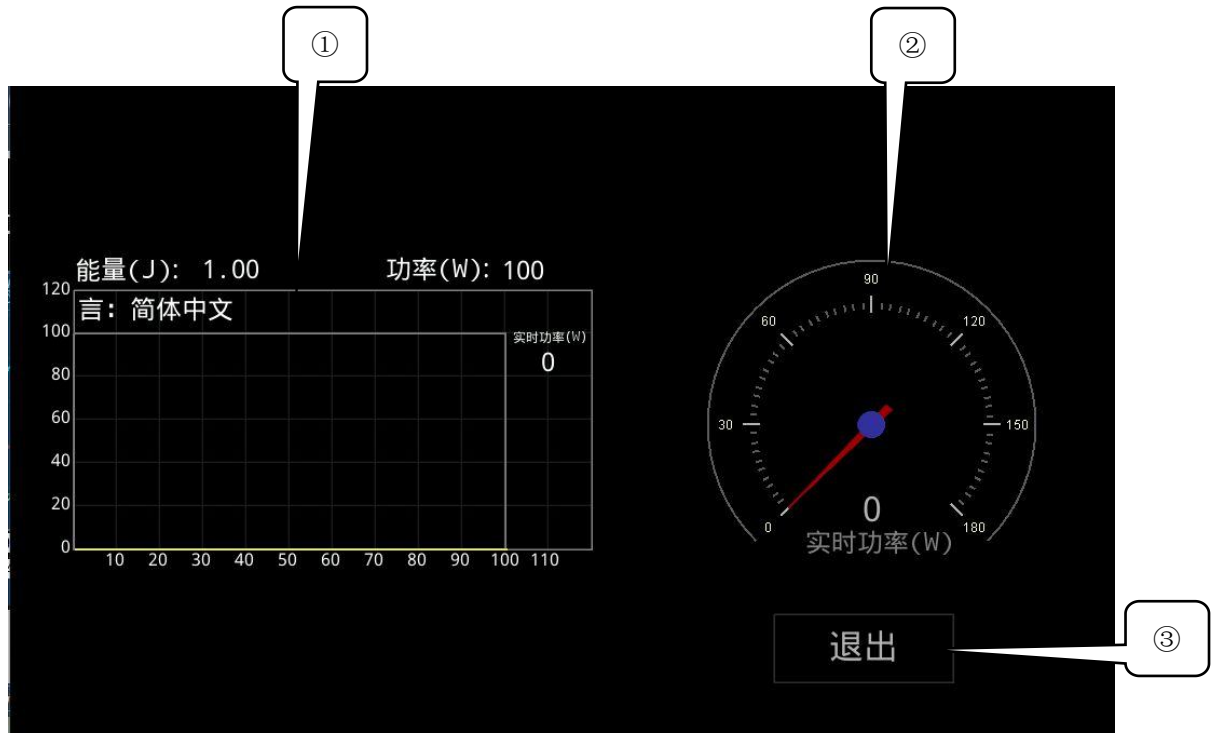

Figure 7-14 / Screensaver display diagram

1.13 Screensaver screen display description

- ① Real-time temperature, dynamic display, PD voltage, voltage and current monitoring;
- ② real-time power monitoring;
- ③ Click to exit the screensaver interface;

2,150W laser

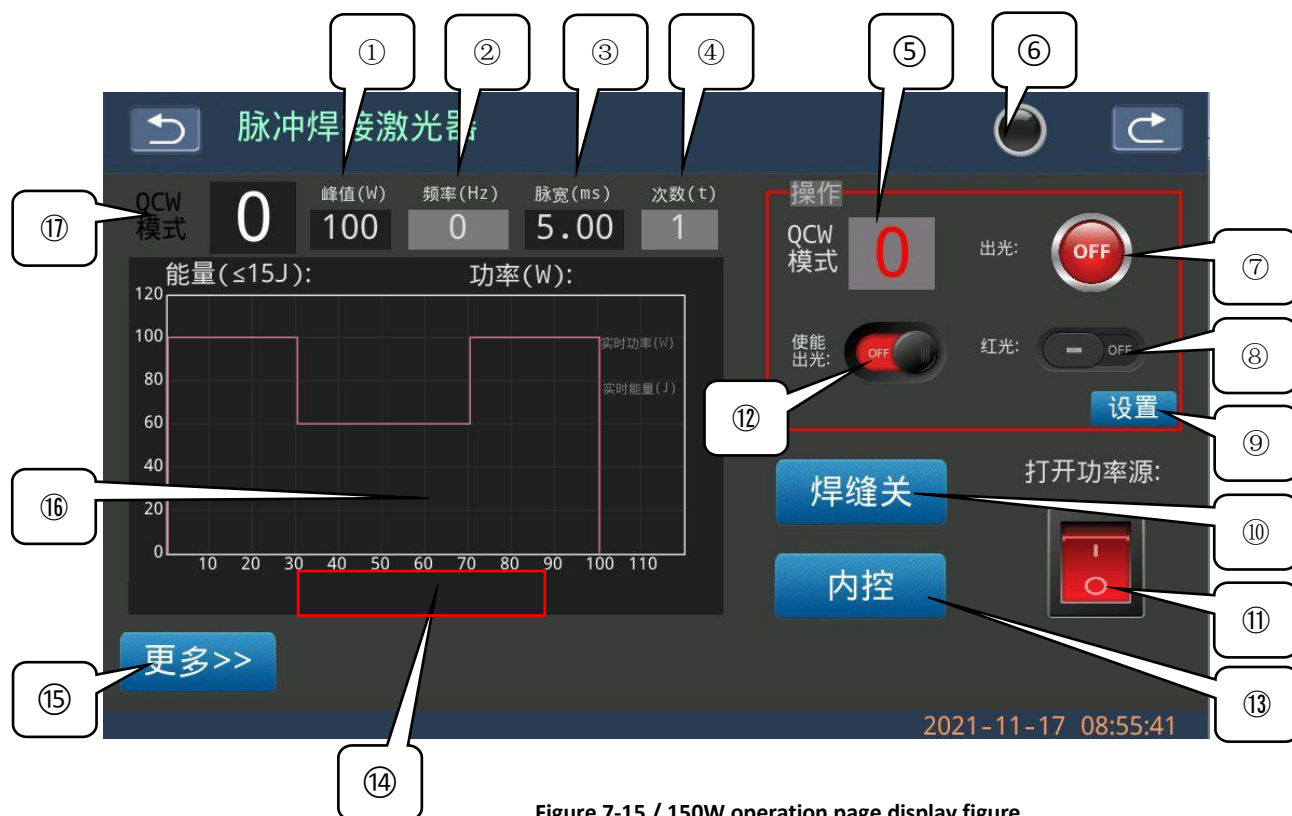

Figure 7-15 / 150W operation page display figure

2.1 Operation page display description

- Set and adjust the ① laser peak parameters, and adjust the step to 1;
- ② frequency parameter of pulse. When the frequency is 0, the default laser is the maximum frequency;
- Setting and adjustment of ③ pulse width parameters, the adjustment step is 0.01;
- ④ Number of light output times set for a single pulse;
- The ⑤ touches this icon to enter the waveform selection, and the background can store 16 sets of waveforms;
- ⑥ communication indicator; flashing green light indicates no communication, gray light indicates no communication;
- The ⑦ touches this icon to trigger "light" and "stop light";
- The ⑧ turns the red light on or off;
- The ⑨ can set the red light strength;
- ⑩ sets any slow rise and slow drop time, and the weld mode should be closed when single light;
- The ⑪ start-up power source key;
- ⑫ enables the light out switch, and it should start the power source before opening;
- ⑬ internal control and external control switch; changing setting parameters should be changed to internal control, internal control is touch screen control light, and external control is external DB25 / IO port control light;
- ⑭ prompts error message; click to enter the alarm information record;
- ⑮ Click "More" to enter the password login, serial number input; the password is 6;

- ⑩ set power waveform and real-time power waveform display area;
- ⑪ QCW / PWM switch key;

Note: Start laser out laser sequence: click "Start power source" click "enable light" click "light" button to give light.

3.100W dual-light path laser



Figure 7-16 / Display figure of the dual-light circuit operation page

3.1 Operation Display Page

- ① # 1 machine operating area;
- ② # 2 machine operating area;
- ③ tick here and A machine synchronization light;
- ④ Click here to enter the password login, serial number input; the password is 6;

Note: Please refer to the 50W~120W operation page for other operation modes.

4、Single screen and dual machine (one support or two)



Figure 7-17 / single-screen dual-machine laser operation page display figure

4.1 Page display description

- ① Click here to enter the Q1 channel page;
- ② Click here to enter the Q2 channel page;
- ③ Click here to enter the dual-channel page;
- ④ Q1 channel page [please refer to Figure 7-4] for operation instructions;
- ⑤ Q2 channel page [please refer to Figure 7-4] for operation instructions;
- ⑥ Q1, Q2 dual-channel page, can operate simultaneously;

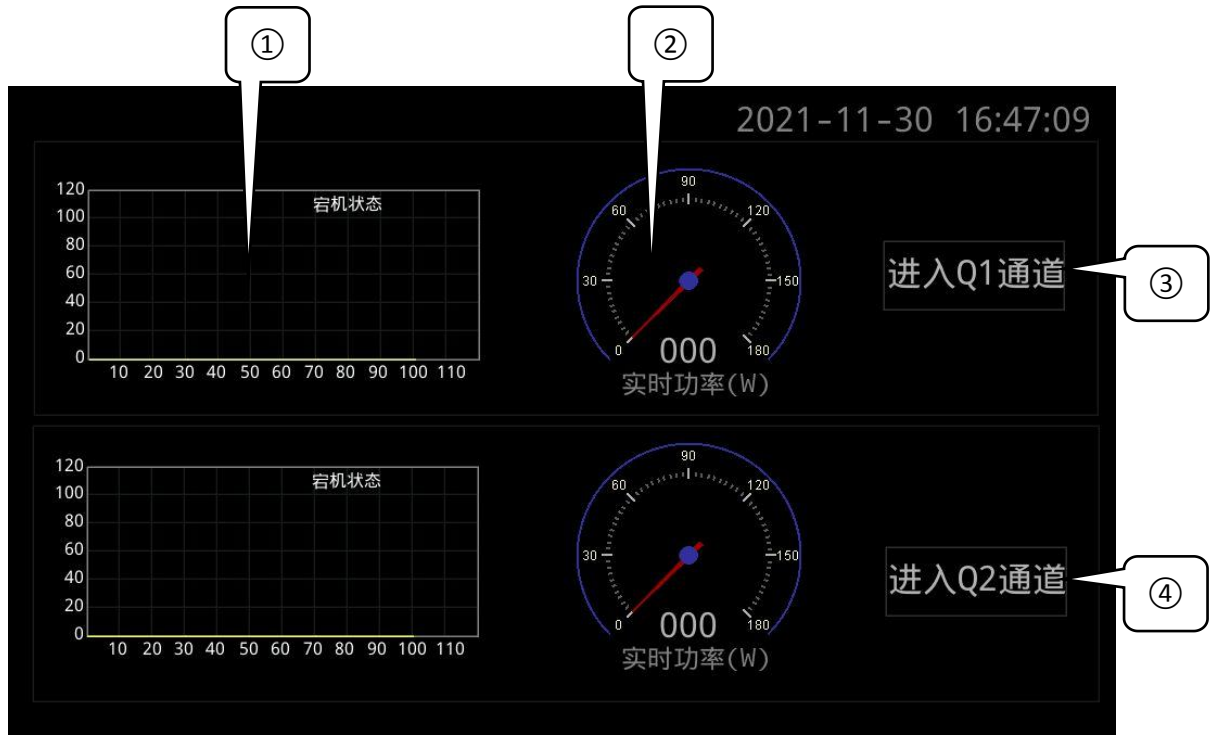

Figure 7-18 / Single-screen dual-machine laser screensaver display diagram

4.2 Dual-channel screensaver display

① Real-time temperature, dynamic display, PD voltage, voltage and current monitoring;

② real-time power monitoring;

③ Click to enter the Q1 channel page;

④ Click to enter the Q2 channel page;

Viii. Troubleshooting

Warning message prompt:	Description and treatment methods:
The lock is not open, please check for 0	Click the start power source key to unlock the lock
Emergency stop, please check the 1	The emergency stop button has been pressed; open the
Power source startup failed, please	Restart the power source to the ON
Fan fault 3	Check the heat dissipation fan
Please contact the manufacturer for the	Tip for an upcoming program upgrade (prompt for three
The program needs to be upgraded,	Please contact the manufacturer
Motherboard temperature is too high	Check the cooling environment of the laser
Motherboard temperature failure 7	Check the laser motherboard temperature sensor
Press the press, please close 8	Turn off to OFF and then on, please start the power
The lock is on, please close 9	Turn off Start Power Source to OFF and then turn on
The QBH error was found at 10	Check the QBH interface; (refer to Chapter 4 laser output head installation)
No energy was detected in the PD 11	Restart the laser; contact the manufacturer
PD detected excessive light energy 12	Restart the laser; contact the manufacturer
Laser temperature is too high 13	Check the cooling environment of the laser, and restart
Laser temperature failure 14	Check the laser temperature sensor
External input frequency is too large 15	The external signal frequency is higher than the laser setting frequency, reducing the external input frequency
Energy power is set at too large as 16	Check the peak value, frequency, and pulse width
The excitation current is too low, check	After enabling light to OFF, reopen to ON
Not key 18	Did not powered to ON
A machine laser fault 19	Restart the laser; contact the manufacturer
B machine laser fault 20	Restart the laser; contact the manufacturer
Machine A is not ready for the 21	Clear the alarm information and restart the power source;
Machine B is not ready for the 22	Clear the alarm information and restart the power source;
Drive board communication exception	Restart the laser; contact the manufacturer
Drive plate temperature failure 32	Check the laser temperature sensor; check the cooling
Drive plate temperature is too high 33	Check the heat dissipation environment of the laser, and restart after the laser drops down naturally;
Laser temperature failure 34	Check the laser temperature sensor; check the cooling
Laser temperature is too high: 35	Check the heat dissipation environment of the laser, and restart after the laser drops down naturally;

2 # Laser temperature fault 36	Check the laser temperature sensor; check the cooling
The 2 # Laser temperature is too high 37	Check the heat dissipation environment of the laser, and restart after the laser drops down naturally;
QBH error # 38	Check the QBH interface; (refer to Chapter 4 laser output head installation)
2 # QBH Error 39	Check the QBH interface; (refer to Chapter 4 laser output head installation)
The energy was not detected in the PD	Restart the laser; contact the manufacturer
PD detected excessive light energy 41	Restart the laser; contact the manufacturer
No energy was detected in the 2 # PD	Restart the laser; contact the manufacturer
2 # PD detected excessive light energy	Restart the laser; contact the manufacturer
Fan failure 46	Please check the fan
Bus voltage is too high 48	Restart; start the power source to ON; clear the alarm
Bus voltage is too low 49	Restart; start the power source to ON; clear the alarm
Input voltage high 50	If the drive plate is abnormal, restart the laser; contact
Input voltage is too low 51	If the drive plate is abnormal, restart the laser; contact
Pump 1 open 52	Restart the laser; contact the manufacturer
Pump 2 open 53	Restart the laser; contact the manufacturer
Pump 3 open 54	Restart the laser; contact the manufacturer
Pump 4 open 55	Restart the laser; contact the manufacturer

Table 8-1 Warning information processing

9. Optical output optical fiber terminal is equipped with air-cooled QBH terminal products

The QBH optical fiber output terminal (Figure 9-1-QBH optical terminal output) is equipped with a protective cover to protect the optical end surface and the electrodes transmitting the optical fiber internal security circuits when not in use. When connected to the external optical head, the protective cover must be removed. This protective cover should be removed before optical cleaning and immediately fixed to the cleaning device for cleaning.

QBH fiber output terminal with protective window blade. For order to avoid contamination and not in use, protective covers.

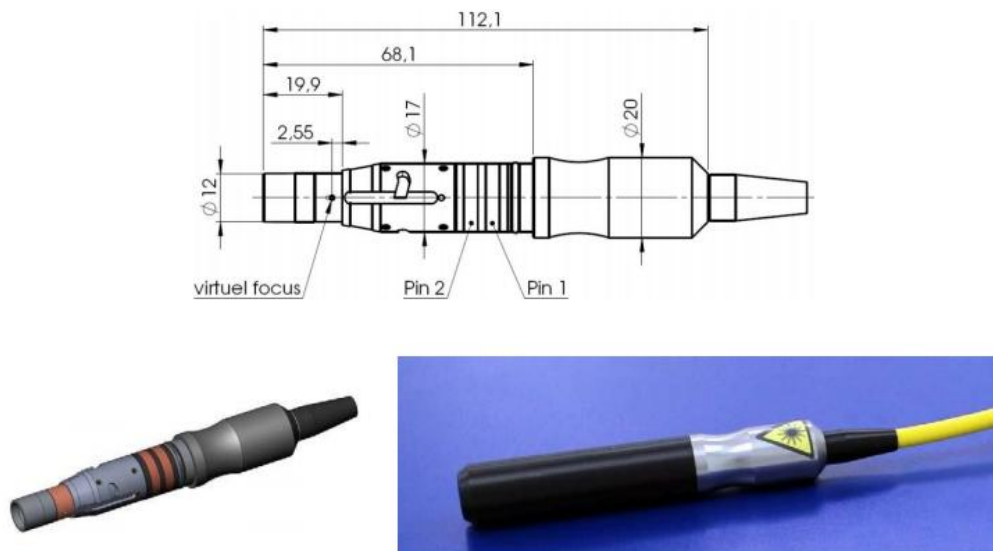

Figure 9-1-QBH end output

Products equipped with a collimator

A collimator (Figure 9-1 collimator output) is equipped with a protective lens that can be replaced if damaged. The protection cover of the collimator must be removed before use, and must be covered when the equipment is not in storage. Protective lenses can be cleaned as required. For cleaning materials and methods, refer to [Fiber End Inspection and Cleaning Guide].

十、work pattern

Both local or remote controls have two main laser operating modes: modulation (PWM) and pulse (QCW). Pulse mode (only for QCW products, pulse mode) inside the product. Pulse width and repetition rate can be set in the following ways:

- Select the laser working mode through the screen (setting button).

The biggest difference between pulse and modulation mode is that the peak is the same (see product specification and [Figure 10-1 pulse mode working range]); while in modulation mode, the QCW maximum single pulse power (J) maximum (pulse width X peak) is fixed, and the PWM high frequency power is only related to the duty cycle and peak, regardless of the frequency.

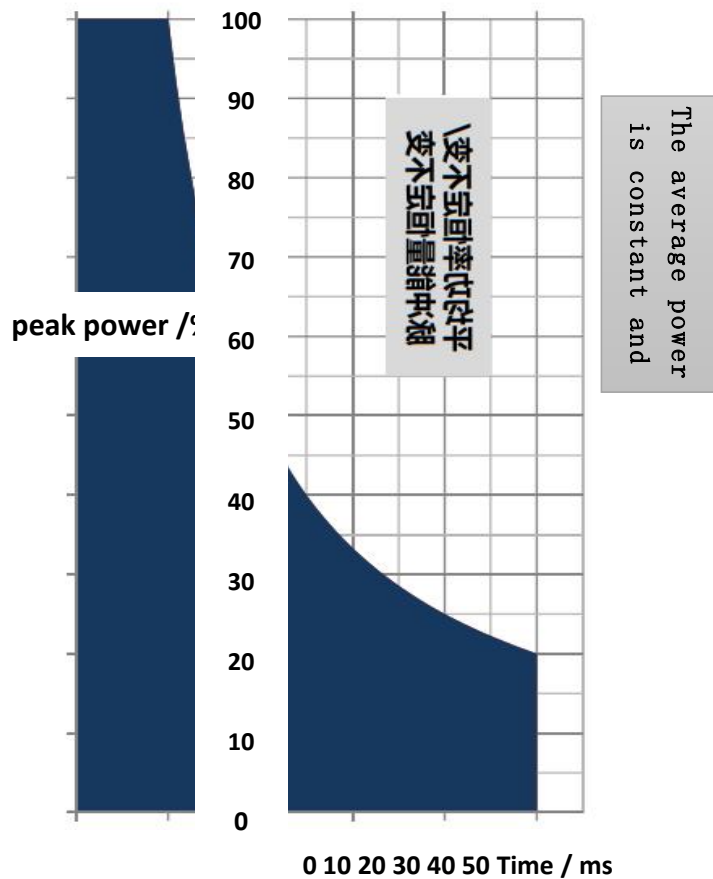

Figure 10-1 Operating range of the pulse mode

In either pulse or modulated laser operating mode, they have 4 seed operating modes: single-machine operation (internal control), modulation, Gate control, and external power (analog) control.

The main difference between these sub-modes is how to set the laser power and switch the laser: the modulation mode (the pulse mode is off), and the laser produces a continuous laser.

十一、 Fiber-optic end inspection and cleaning guide



Caution 注意

It is important to check the optical fiber connector for dust, dirt, or damage each time before connecting it to the external optical head or optical coupler. Use with dirty or improper cleaning can cause serious damage to the laser.(For common examples of optical fiber quartz block damage, see [Figure 11-1 Optical fiber quartz block inspection]). The Company is not responsible for any damage caused by end contamination. Those who tamper with the optical fiber terminal without professional engineer training, shall not be responsible for warranty.

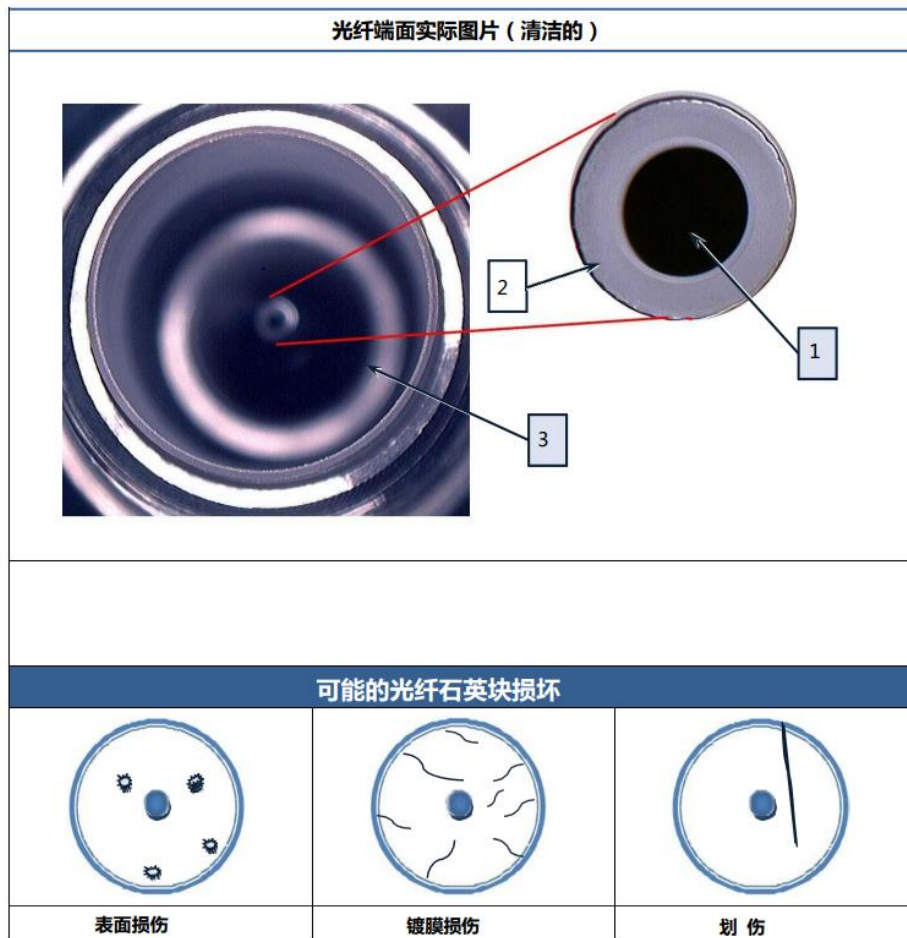

Figure 11-1 Optical Fiber Quartz Block Inspection

- (1) Quartz block
- (2) fibre cladding
- (3) Optical fiber core

Clean the optical fiber terminals, and you need to prepare the following materials:

- No powder latex gloves or finger covers;
- Optical grade cleaning paper and cleaning rod;
- Acetone (optical grade, anhydrous);
- Isopropane alcohol (optical grade, no water);
- Compressed air (no oil, no water);
- microscope;
- secondary light source;

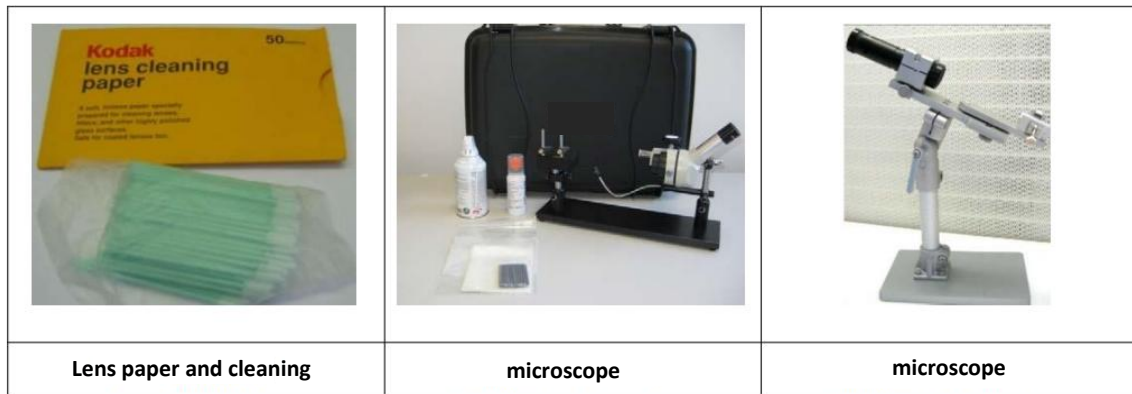

Figure 11-2 Cleaning Materials

important information:

- **Wear powder-free latex gloves during the cleaning operation!**
- **This statement states that improper handling, improper cleaning operations, or cleaning with other chemicals may cause damage to the optical fiber terminals, which is not covered by the warranty.**
- **Acetone should be managed and stored in accordance with local regulations, and check safety data for the chemicals.**

1. Press the E-Stop button on the front panel to cut off the laser main power supply and unplug the AC power cable.
2. Before removing the protective cover, clean the outside of the optical fiber end with some optical cleaning paper, and then blow it dry with compressed air.
3. Position the fiber optic end in the holder of the microscope and press the middle of the fixing screw as shown in the figure below.



Figure 11-3 Optical fiber ends are fixed with the microscope

4. Remove the protective cover and aluminum protective sleeve of the optical fiber terminal, as shown in the figure below.

Important: The protective cover should be placed mouth-down on a clean plane. If the table top is not suitable, the best way is to pad a sheet of optical cleaning paper.



Figure 11-4 Remove the optical fiber protective cover and aluminum protective sleeve

5. Adjust the focal length of the microscope to focus it on the surface of the end.
6. Light up the optical fiber end surface with an auxiliary light source, and adjust the Angle of the light source to reflect it into the microscope. This way you can see a golden yellow or blue bright surface from the microscope.

Important Information: Please always keep a small angle from the end surface for easy observation.

- 1、 Check the end surface carefully. Any contamination on the end surface can cause black spots and eventually cause damage to the optical fiber (see, for an example, [Figure 11-4]). If there is visible contamination of the quartz surface, please proceed to the next step. If there is no visible contamination, skip directly to step 14.
- 2、 Try blowing the dust away from the side with compressed air.

Important: Never use compressed air to blow directly against the quartz end, which may embed the pollution in the end surface. Be sure to blow from the side, airflow across the surface.

9. Bring powder-free latex gloves, then remove a piece of optical cleaning paper and fold it into a rectangular shape of about 2.5x4cm (as shown in [Figure 11-5]). Then drop a few drops of isopropanol on the neatly folded edge;

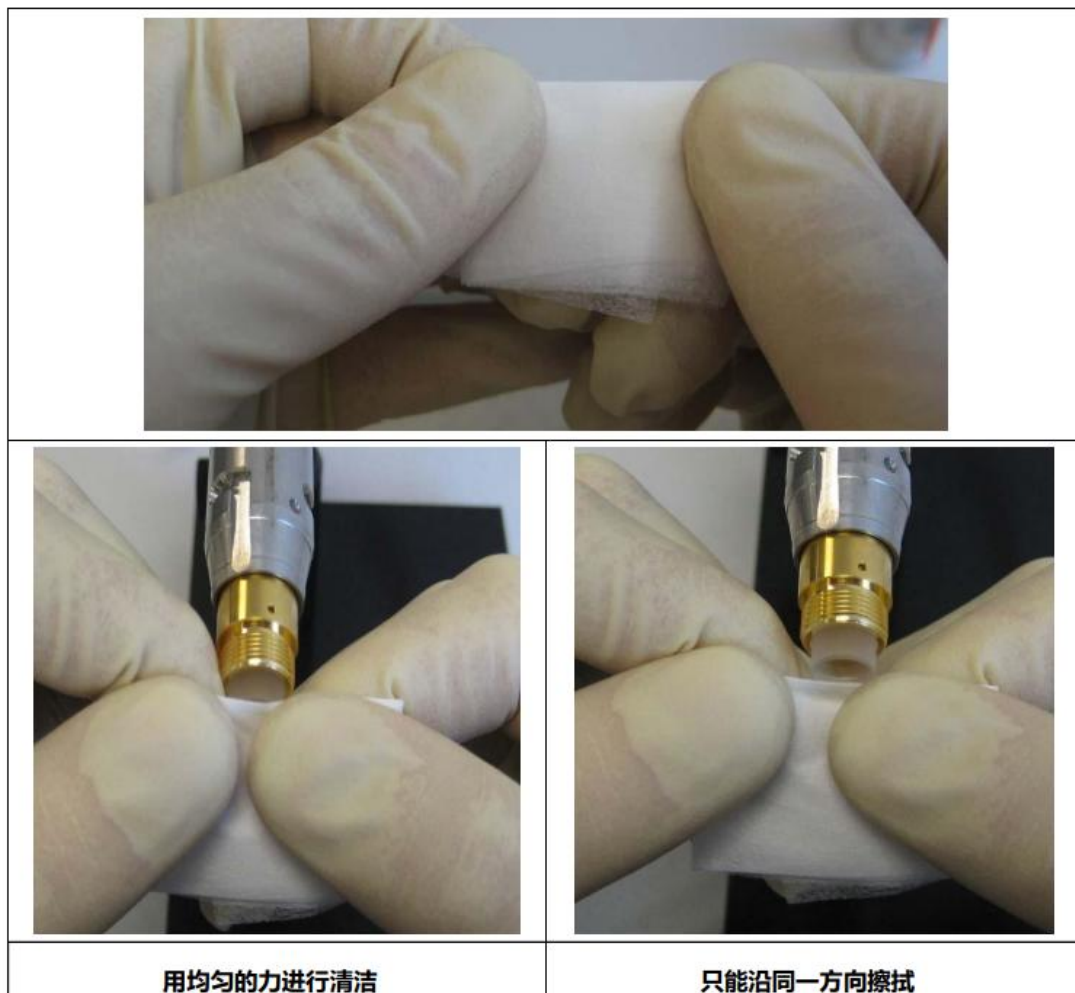

Figure 11-5 Fiber fiber surface cleaning

Important: Never reuse optical cleaning paper and cleaning sticks during cleaning.

10. Check again whether the end surface is still polluted.
11. If the contamination is still difficult to clean, repeat step 9 with acetone.
12. If necessary, drop a drop of acetone on the optical cleaning rod, and then gently

remove the pollution by circular movement. Be careful not to scratch the end surface. Then return to step 9 operation.



Caution 注意 Do not touch the end of the cleaning bar with your hands, and do not reuse the cleaning bar to avoid contamination.

13. Repeat the above operations until the pollution of the end surface is removed. If the cleaning requirements have been met, you can stop this cleaning procedure at any time. After cleaning the end surface, clean the aluminum protective casing with compressed air away from the optical fiber end head to avoid polluting the end surface again, and then install it on the optical fiber end head.

14. Connect the optical fiber terminal to the external optical head (see [Figure 4-2QBH terminal operation diagram and installation for details])

15. If you do not want to connect the optical fiber end to the external optical head immediately, please clean the protective cover with compressed air and reinstall the optical fiber end again.

Important: Don't forget to clean the protective cover and aluminum protective sleeve back to the fiber terminals.

十二、 Service and maintenance

1. Instructions for maintenance

- (1) This product has no parts, parts or components to be repaired by users, and all maintenance operations shall be completed by our professionals.
- (2) In order to protect your rights and interests, please contact our company or the local representative as soon as possible after discovering the fault, and apply for product maintenance or replacement service. After the authorization from our company, please match the warranty products and send them back to our company.
- (3) When any damage is found after receiving the product, supporting documents must be left to claim the rights against the carrier.
- (4) Do not send any products back to our company without communication and confirmation.
- (5) If the product is not covered by the warranty period or the warranty scope, the customer shall be responsible for the product maintenance costs.
- (6) Our company has the right to change any design or structure of the product, subject to change without notice.

2. Warranty restrictions

Products, components (including fiber connectors) or equipment are not covered by the warranty if:

- (1) Being artificially tampered with, opened, disassembled or transformed by personnel outside our company;
 - (2) Damage caused by improper use, negligence or accident;
 - (3) Use beyond the scope of product specifications and technical requirements;
 - (4) The laser damage is indirectly caused by the user software or interface failure;
 - (5) Due to incorrect installation, repair or other abnormal operating conditions not included in this manual;
 - (6) Accessories and optical fiber optic connectors are not covered by the warranty.
- The above information requires the customer to clarify and follow the user instructions, otherwise the product failure will not be covered by the warranty.

3. Service statement

For our product safety, setting, operation or maintenance issues, please read

this manual carefully and strictly follow the operation instructions. We will constantly develop new products, and the product information listed in the instructions is subject to change without notice. All technical parameters shall be subject to the contract terms.

The above product warranty and service terms of our company are for user reference only, and the formal service and warranty content shall be subject to the provisions in the contract.

For any questions, please call our customer service department. Your feedback problems will be confirmed by our customer service department, and will be followed up by the technical support team. If your problem still cannot be solved after communication with the technical support group, you may need to send the product back to our company for in-depth investigation.

**All of the above information and terms interpretation right
belongs to our company**

<u>edition</u>	<u>Update content</u>	<u>Edit the date</u>
V1.00	First release	2021.08.24
V1.01	Add security information, installation method, and serial number input	2021.09.03
V1.02	Add 150W, 100W dual-light path laser instructions	2021.12.02